

PHILIPS

CoreLine Trunking Gen2

LL212X, LL217X, LL234X

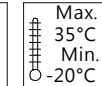
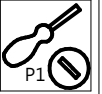
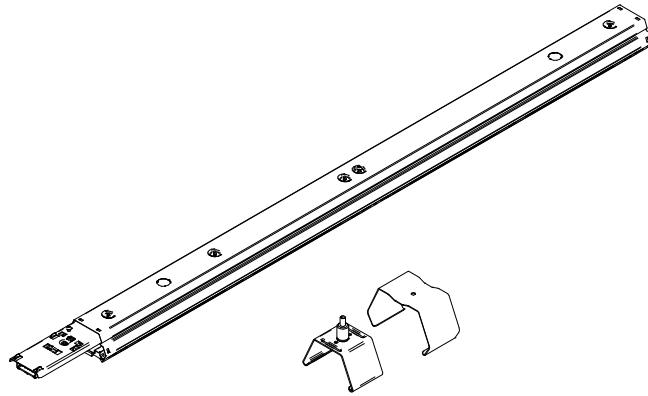

GLOW WIRE
850°C

! Prevent water from entering on or in the luminaire at installation and during use of the luminaire.

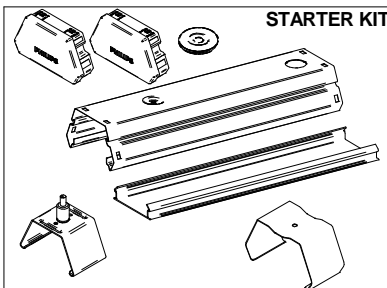
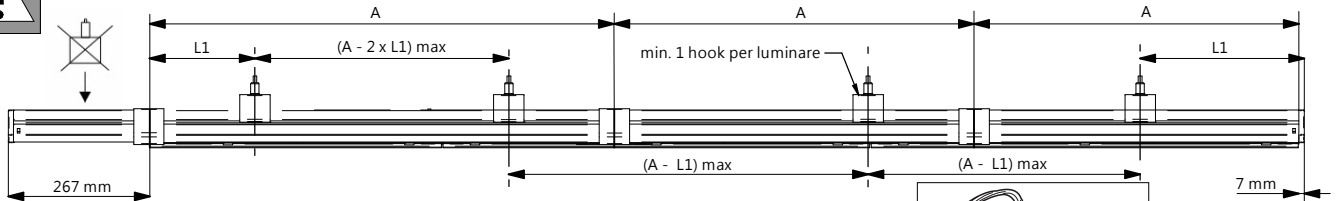

max 2,5 mm²



Starter kit is ordered separately depending on the matching version

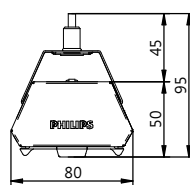
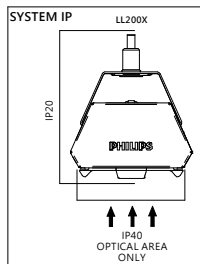

Steel wire
*its not part of starter Kit
*can be ordered as an accessory

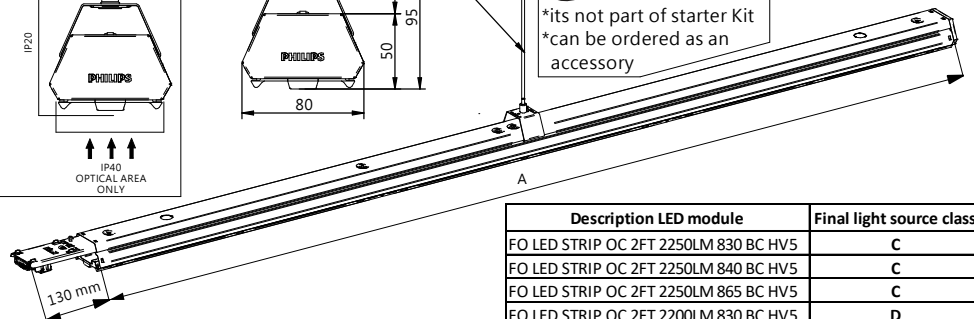

Description LED module	Final light source class
FO LED STRIP OC 2FT 2250LM 830 BC HV5	C
FO LED STRIP OC 2FT 2250LM 840 BC HV5	C
FO LED STRIP OC 2FT 2250LM 865 BC HV5	C
FO LED STRIP OC 2FT 2200LM 830 BC HV5	D
FO LED STRIP OC 2FT 2200LM 840 BC HV5	D
FO LED STRIP OC 2FT 2200LM 865 BC HV5	D

Luminaire type	System flux [lm]	Wattage [W]	A [mm]	L1 [mm]	kg
LL212X	30S PSU	3.000	1130	200 - 400	2,3
	53S PSU N/HE	5.300			2,3
	80S PSU N/HE	8.000			2,3
	30S PSD/SRD	3.000			2,4
	53S PSD/SRD N/HE	5.300			2,4
	80S PSD/SRD N/HE	8.000			2,4
LL217X	45S PSU N/HE	4.500	1700	500 - 800	2,8
	80S PSU	8.000			2,8
	120S PSU N/HE	12.000			2,8
	45S PSD/SRD	4.500			2,9
	80S PSD/SRD N/HE	8.000			2,9
	120S PSD/SRD N/HE	12.000			2,9
LL234X	90S1xPSU	9.000	3400	500 - 800	5,4
	160S 1xPSU	16.000			5,4
	240S 1xPSU	24.000			5,4
	90S 2xPSU	9.000			5,5
	160S 2xPSU N/HE	16.000			5,5
	240S 2xPSU N/HE	24.000			5,5
	90S 1xPSD/SRD	9.000			5,4
	90S 2xPSD/SRD	9.000			5,4
	160S 1xPSD/SRD N/HE	16.000			5,6
	160S 2xPSD/SRD N/HE	16.000			5,6
	240S 1xPSD/SRD	24.000			5,7
	240S 2xPSD/SRD N/HE	24.000			5,8

442710401342

12/ 2020, Signify Holding All rights reserved

Installation - all steps

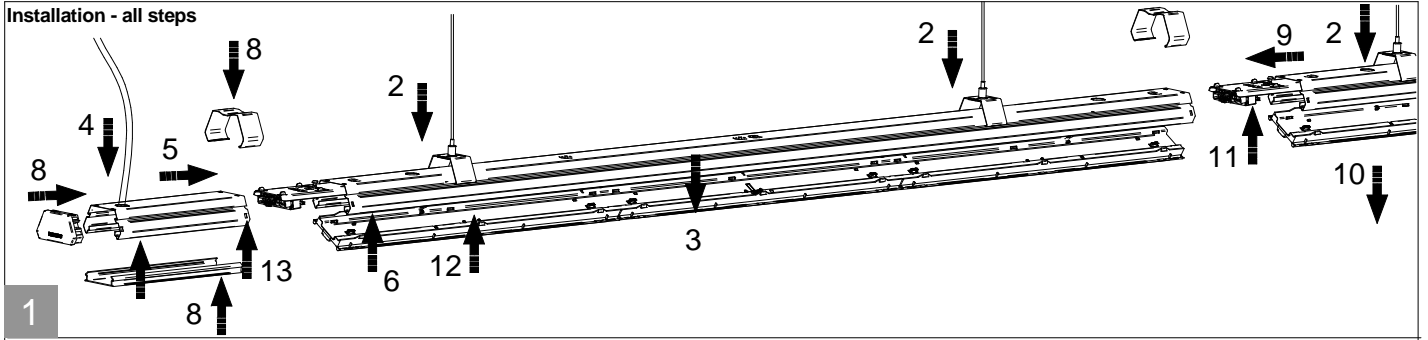

Drawing	Accessories
2a	LL200Z MB-SW
2b	LL200Z CB
2c	LL200Z SMB
2d	LL200Z PB
2e	LL200Z SMB-TPM SET

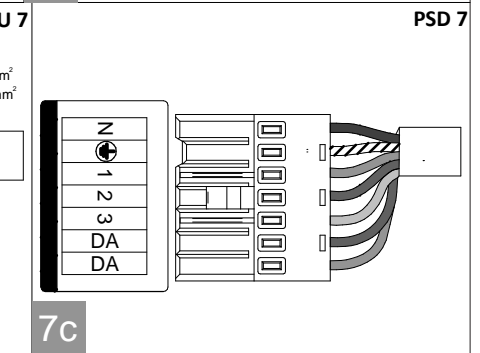
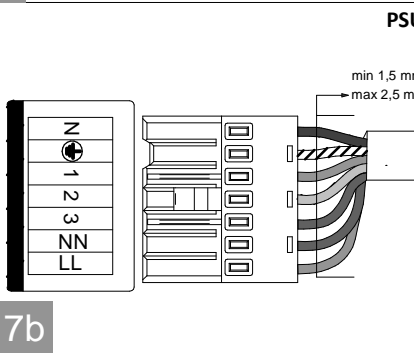
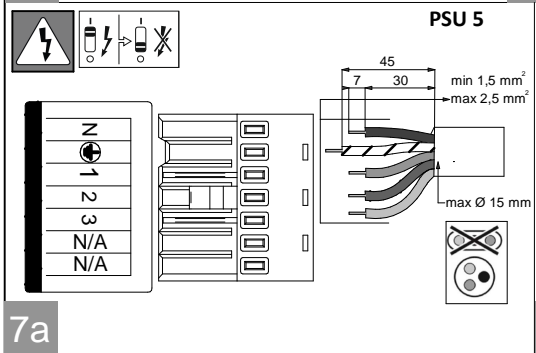
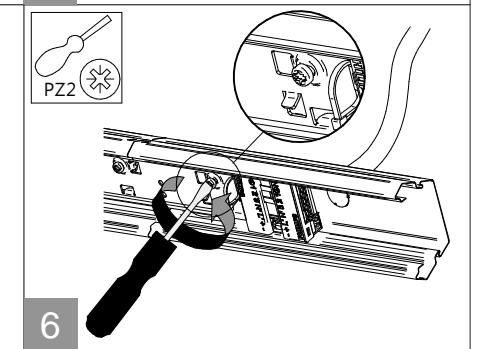
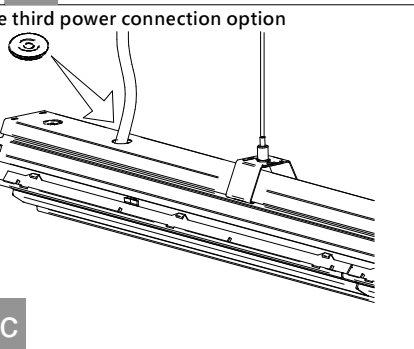
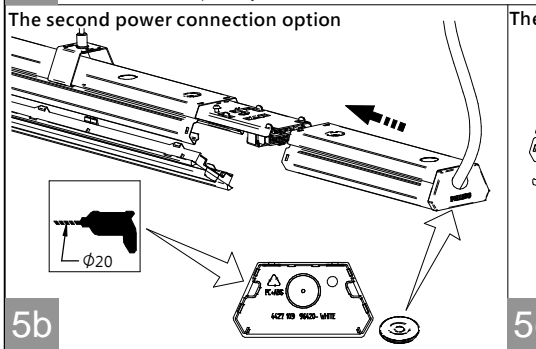
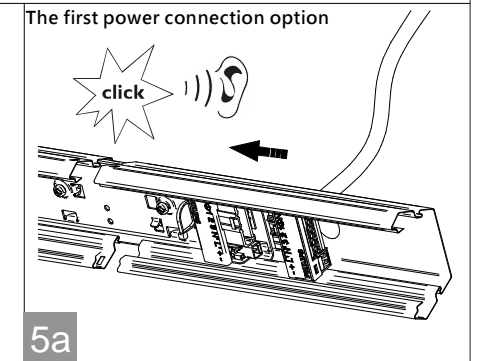
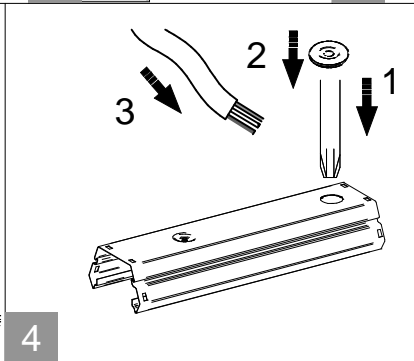
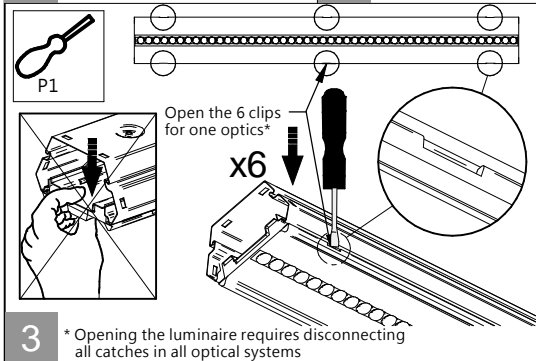
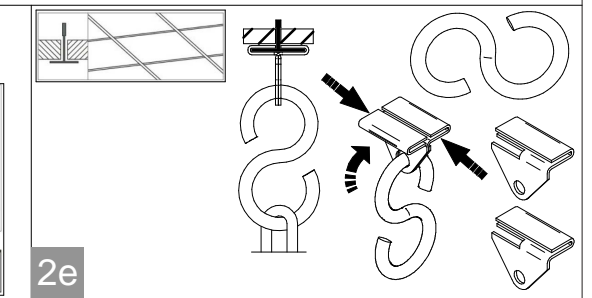
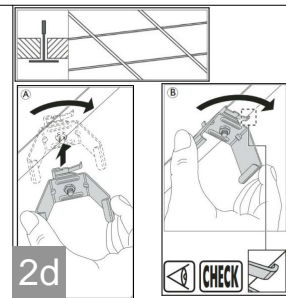
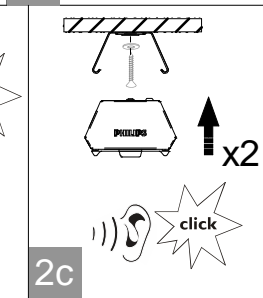
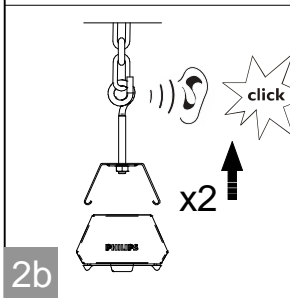
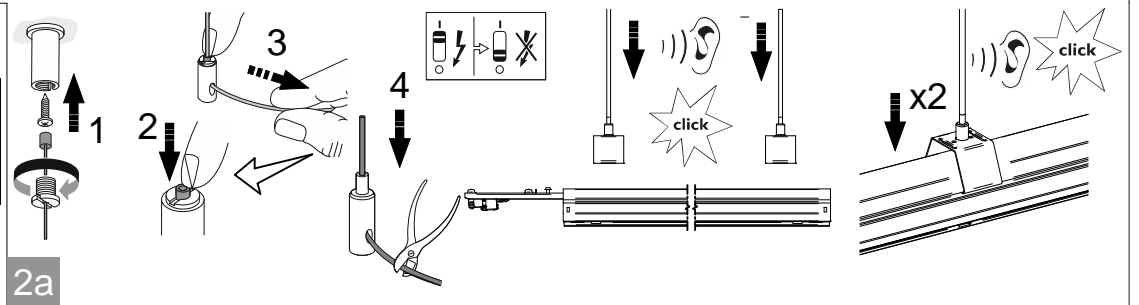

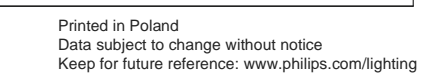
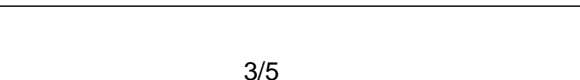
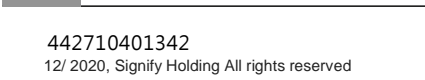
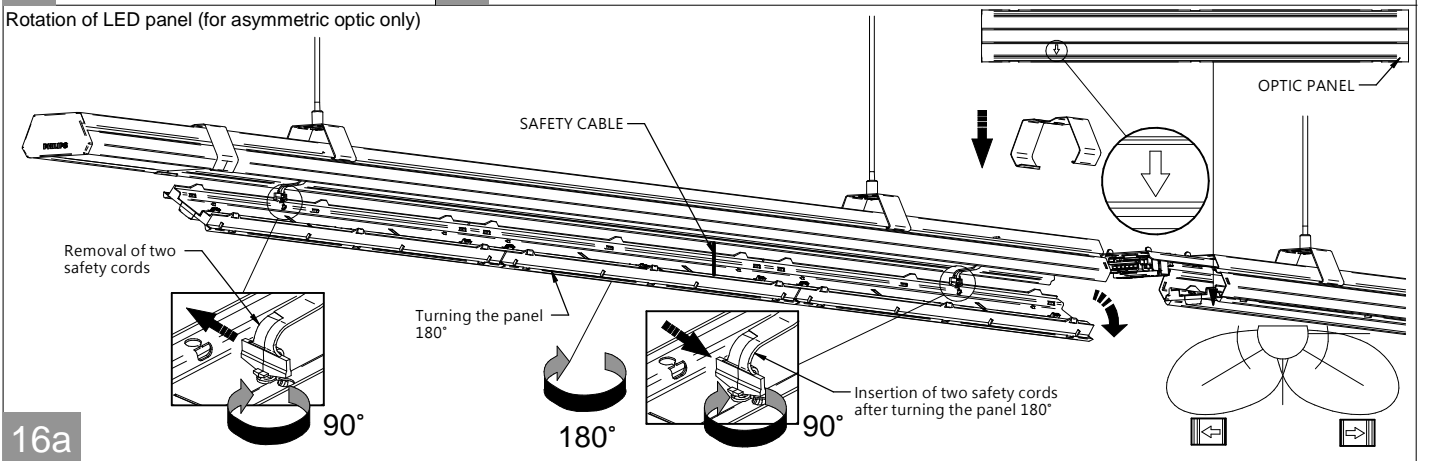
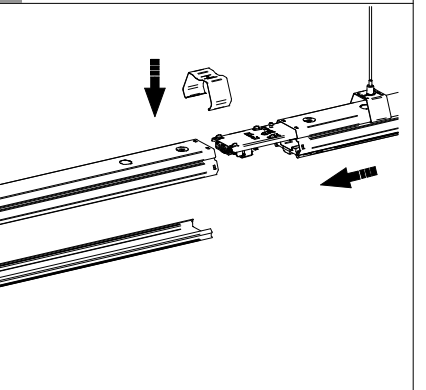
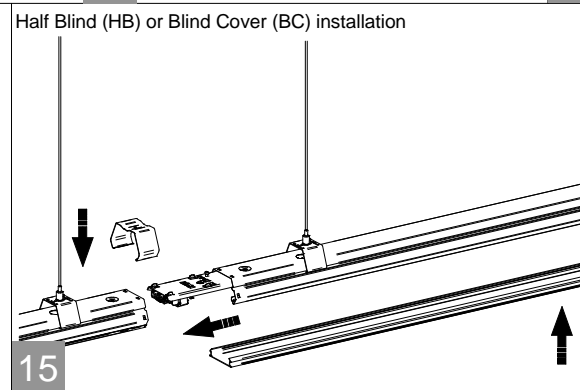
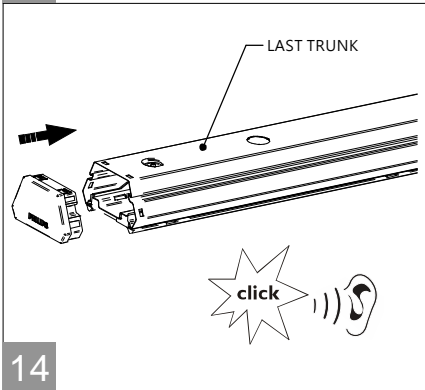
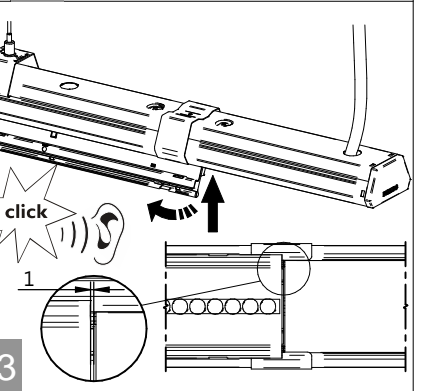
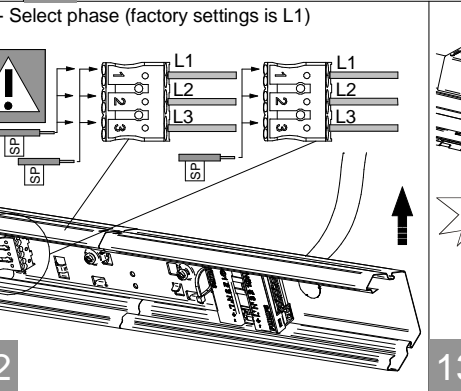
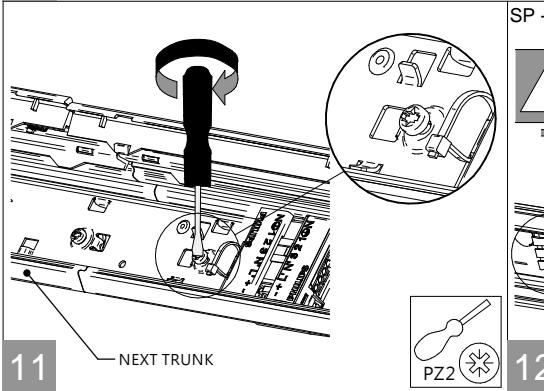
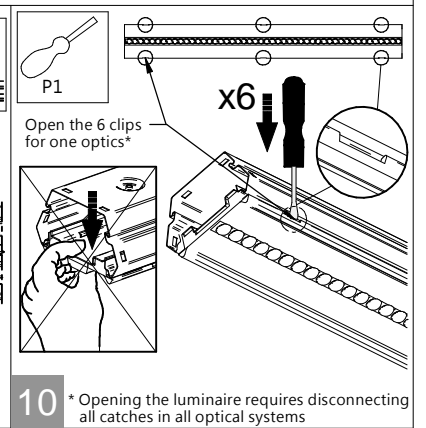
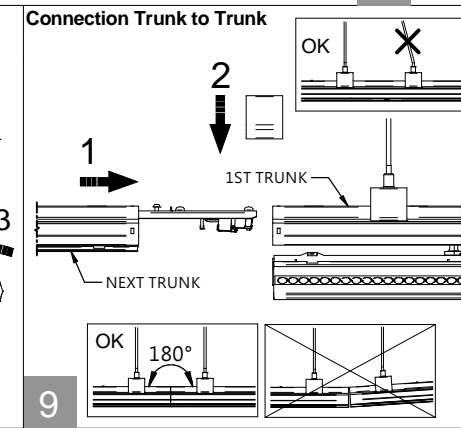
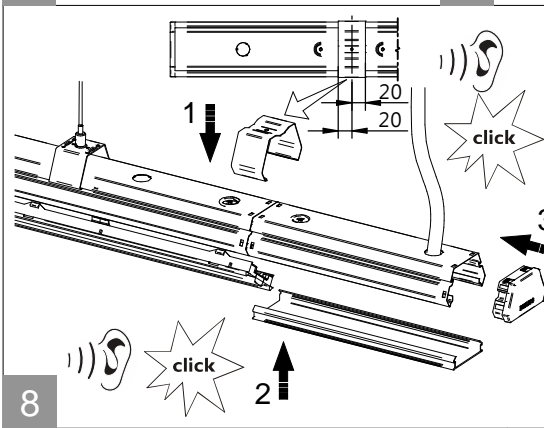
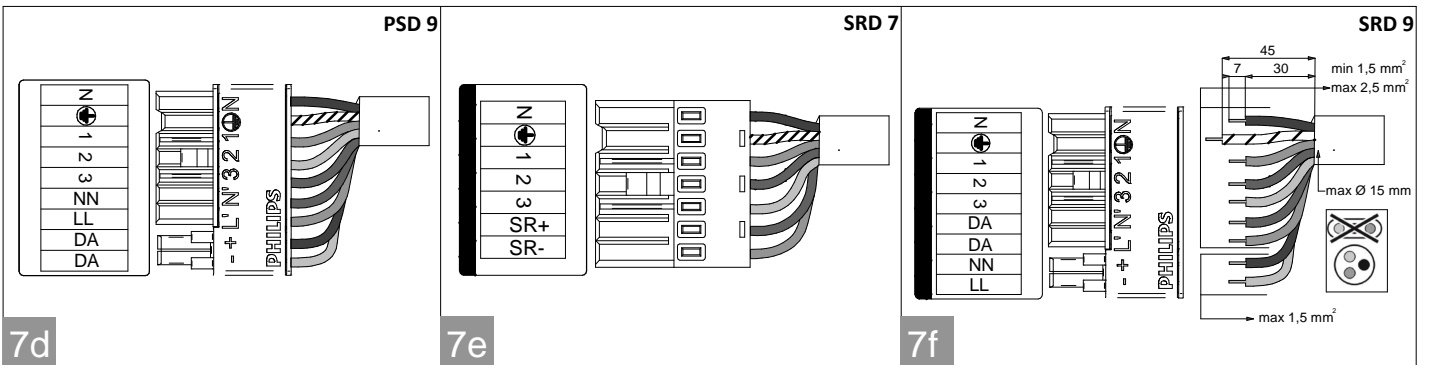

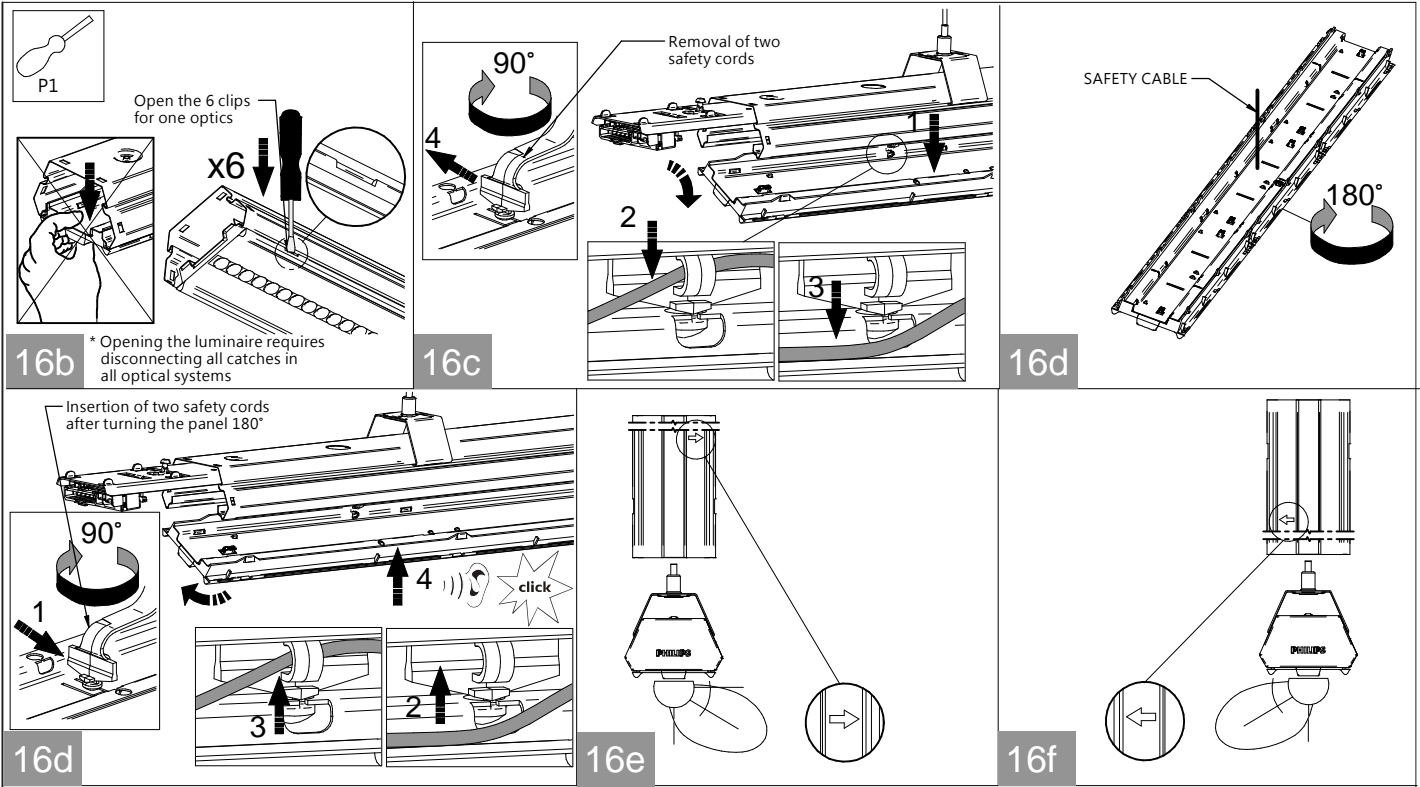

Inrush current

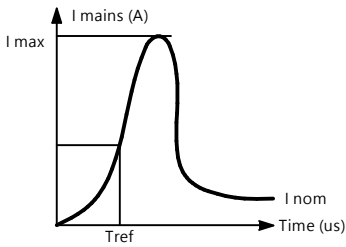

TYPE	535 1xPSU (36W)	305/455 1xSRD (35W)	905 2x SRD (35W)	305/455 1xPSD (35W)	905 2xPSD (35W)	305/455/535/805 1xPSD (60W)	905/1605 2xPSD (60W)	535/805 1xSRD (60W)	1605 2xSRD (60W)	455/805 1xPSU (75W)	905/1605 2xPSU (75W)	805/1205 1xPSU (100W)	2405 2xPSU (100W)	805/905/1205 1xPSD (100W)	2405 2xPSD (100W)	805/905/1205 1xSRD (100W)	2405 2xSRD (100W)	805/1205/1605 1xPSD (150W)	2405 2xPSD (150W)	1605 1xSRD (150W)
I _{max} [A]	14,0	21,0	42,0	23,1	46,2	25,1	50,2	21,0	42,0	19,0	38,0	22,5	45,0	10,0	20,0	4,5	9,0	5,1	10,2	5,1
T _{ref} [µs]	250	280	280	221	221	214	214	280	280	280	280	30	30	35,9	35,9	1000	1000	760	760	760
cable Ø [mm ²]	1,5 / 2,5*																			
MCB B-6A	13/13	8/8	4/4	8/8	4/4	8/8	4/4	8/8	4/4	9/9	4/4	9/9	4/4	7/7	3/3	7/7	3/3	6/6	3/3	4/4
MCB B-10A	20/20	13/13	6/6	13/13	6/6	13/13	6/6	13/13	6/6	15/15	7/7	14/14	7/7	11/11	5/5	11/11	5/5	10/10	5/5	7/7
MCB C-10A	34/34	21/21	10/10	22/22	11/11	21/21	10/10	21/21	10/10	24/24	12/12	23/23	11/11	18/18	9/9	18/18	9/9	16/16	8/8	12/12
MCB B-13A	26/26	17/17	8/8	17/17	8/8	17/17	8/8	17/17	8/8	19/19	9/9	18/18	9/9	14/14	7/7	14/14	7/7	12/12	6/6	9/9
MCB C-13A	40/44	28/28	14/14	29/29	14/14	28/28	14/14	28/28	14/14	32/32	16/16	30/31	15/15	24/24	12/12	24/24	12/12	20/21	10/10	16/16
MCB B-16A	33/33	21/21	10/10	22/22	11/11	21/21	10/10	21/21	10/10	24/24	12/12	23/23	11/11	18/18	9/9	18/18	9/9	16/16	8/8	12/12
MCB C-16A	40/56	35/35	17/17	37/37	18/18	35/35	17/17	35/35	17/17	40/40	20/20	30/39	15/15	30/30	15/15	30/30	15/15	20/27	10/13	20/20

* Warning! The values on the left are for 1.5 mm thick cables, the values on the right are for 2.5 mm thick cables

Maintenance instructions

To assure the lighting quality of this unique LED lighting concept there are a few instructions regarding the maintenance of this LED luminaire:

- Do not touch electronic components!
Electronic components are under high voltage.
Electronic components are ESD sensitive.
- During installation or when maintaining the luminaire please use static free gloves to avoid marks on the luminaire.
- To remove dirt and spots use the following:
Dust: only use micro fiber cloths
Fingerprints, etc.: use a cleaner for synthetic materials with antistatic properties.
- Do not stare into the LED light beam.
- To avoid scratches and dirt on optical parts remove protective foil after installation.
- The luminaire shall be installed by a qualified electrician and wired in accordance with the latest IEE electrical regulations or the national requirements.
- The light source of this luminaire is not replaceable: when the light source reaches its end of life whole luminaire shall be replaced.
- Driver insulation: Basic according to IEC 61847-1.

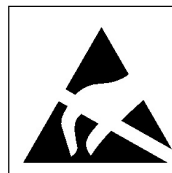
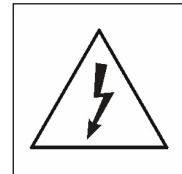
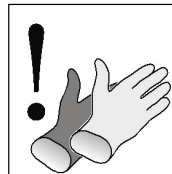

ATTENTION
OBSERVE PRECAUTIONS
FOR HANDLING
ELECTROSTATIC
SENSITIVE
DEVICES



GB- Disconnect before servicing
FR - Mettre hors tension avant intervention
DE - Offennurspannungsfrei
NL- Stroomafsluiten voor onderhoud
LT- Pirms apkopas atvienojiet no elektrības
EE- Katkestaelektritoide enne valvust
hooldust/remonti
PT- Desconecte antes de fazer a manutenção

DK- Frakobl, før service
NO- Koble fra før service
FI- Irrota pistoke ennen huoltoa
CZ- Před servisem se odpojte
TR- Servis yapmadan önce bağlantıyı kesin
HR- Prije servisiranja isključite
GR- Αποσυνδέστε πριν από τη συντήρηση
BG- Изключете преди сервис
RU- Отключите перед обслуживанием
LV- Pirms apkopes atvienojiet to

IT - Toglieretensione prima di fare manutenzione
ES- Desconectar antes de manipular
SE- Bryt strömmen före lampbyte
SK- Odpojit před údržbou
SI- Predservisiranje izključite svetilko
HU- Karbantartás előtt húzza ki a csatlakozót
PL- Odłącz przed serwisowaniem
RO- Deconectați-vă înainte de întreținere

GB Luminaire has basic insulation between Low Voltage supply and control conductors.
ES La luminaria tiene un aislamiento básico entre la alimentación de baja tensión y los cables de la señal de control.
PT A luminária tem um isolamento básico entre a alimentação de baixa tensão e os cabos de sinal de controlo.
DE Die Leuchte verfügt über eine einfache Isolation zwischen der Niederspannungsversorgung und den Steuerleitungen.
FR Le luminaire comporte une isolation de base entre l'alimentation basse tension et les câbles de contrôle.
IT Il grado di isolamento tra il conduttore di alimentazione ed il conduttore di segnale è básico.
NL Armatuur heeft een basisisolatie tussen laagspannings-voeding en controle bedrading.
DK Armaturet har enkelisolering mellem lavvoltsforsyningen og styreledningerne.

SE Armaturen har enkelisolering mellan lågvoltförsörjningen och styreledningarna.
NO Armaturet har enkelisolering mellom lavvoltsforsyningen og styreledningene.
FI Valaisimessa on peruseristys syöttöjännitteen ja ohjausohjelmien välillä.
HU A lámpatest kifizetsültségű és szabályozó bemenetei galvanikusan el vannak választva.
RO Corpul de iluminat dispune de izolație de bază între sistemul de alimentare de joasă și conductorii de control.
BG Осветителното тяло има основна изолация между захранването ниско напрежение и контролните проводници.
RU Светильник обладает базовой электроизоляцией между низковольтным блоком питания и управляющими проводниками.
PL Oprawa posiada podstawową izolację pomiędzy modulem zasilania niskonapięciowego i przewodami sterującymi.

GR Το φωτιστικό διαθέτει βασική μόνωση μεταξύ της χαμηλής τάσης τροφοδοσίας και των αγώγων ελέγχου.
CZ Ve svítidle je mezi vodiči napájení a řízení základní izolace.
TR Armatür, Alçak Gerilim beslemesi ile kontrol ilekleri arasında temel izolasyona sahiptir
SK Svetidlo má základnú izoláciu medzi vodičmi zdroja nízkeho napätia a riadiacimi vodičmi.
LT Šviestuvus turi elementarią izoliaciją tarp žemos įtampos maitinimo ir valdymo laidų.
LV Gaismeklī ir pamata izolācija starp zemsprieguma barošanas un vadības aprīkojuma.
EE Valgustil on põhiisolatsioon madalpinge toite ja juhtimiseadmete vahel.
SI Svetilka ima osnovno izolacijo med nizkonapetostnimi napajalnimi in regulacijskimi vodniki.
HR Svjetiljka ima osnovnu izolaciju između napajanja i upravljačkih konektora.

GB The light source and/or control gear and/or the external flexible cable contained in this luminaire shall only be replaced by the manufacturer or his service agent or a similar qualified person.

RO Sursa de lumină și / sau aparatul și / sau cablul flexibil extern conținut în acest aparat de iluminat trebuie înlocuite numai de producător sau de agentul său de service sau de o persoană calificată similară.

ES La fuente de luz/o el driver / o el cable flexible contenido en la luminaria solo podrá ser sustituido por el fabricante o su agente de servicio o por una persona cualificada.

FI Tässä valaisimessa oleva valonlähde ja/tai muut komponentit, kuten liitäntälaitte ja/tai ulkoiset kaapelit saadaan vaihtaa vain valmistajan tai tämän valtuuttaman huoltoedustajan tai vastaavan pätevä henkilöön toimesta.

PT A fonte de luz e/ou o equipamento de controlo e/ou o cabo externo flexível nesta luminária só devem ser substituídos pelo fabricante ou pelo seu agente de serviço ou por pessoa qualificada para tal.

TR Bu armatürde bulunan ışık kaynağı ve / veya kontrol tertibatı ve/ veya hariç esnek kablo, yalnızca imalatçı veya onun servis temsilcisi veya benzer bir kalifiye kişi tarafından değiştirilmelidir.

DE Die in dieser Leuchte enthaltene Lichtquelle und/oder das Betriebsgerät und/oder das externe flexible Anschlusskabel darf nur vom Hersteller oder seinem Kundendienst oder einer ähnlich qualifizierten Person ausgetauscht werden.

HR Izvor svjetlosti i / ili predspojna naprava i / ili vanjski fleksibilni napojni kabel sadržan u ovoj svjetiljci smije zamijeniti samo proizvođač, ovlašteni serviser ili adekvatna stručno osposobljena i ovlaštena osoba.

FR La source lumineuse et/ou le contrôleur de courant et/ou le câble souple d'alimentation contenus dans ce luminaire ne doivent être remplacés que par le fabricant, un de ses agents ou une personne qualifiée.

GR Η φωτεινή πηγή ή/και τα όργανο έναυσης/ελέγχου ή/και το εξωτερικό εύκαμπτο καλώδιο που περιέχεται στο εν λόγω φωτιστικό πρέπει να αντικαθίστανται μόνο από τον κατασκευαστή ή τον αντιπρόσωπο σέρβις ή παρόμοιο ειδικευμένο πρόσωπο.

IT La sorgente luminosa e/o il dispositivo di controllo e/o il cavo flessibile esterno contenuti in questo apparecchio di illuminazione sono sostituiti solo dal costruttore o dal suo agente di servizio o da una persona qualificata analoga.

BG Източникът на светлина и / или пусково-регулираща апаратура и / или външният гъвкав кабел, съдържащ се в това осветително тяло, трябва да бъдат заменени само от производителя или неговия оторизиран сервис или подобно квалифицирано лице.

NL De lichtbron en/of voorschakelapparatuur en/of de flexibele voedingskabel van dit armatuur mag alleen vervangen worden door de fabrikant of haar service dealer of een vergelijkbaar gekwalificeerd persoon.

RU Источник света и / или ПРА и / или внешний гибкий кабель, содержащиеся в этом светильнике, могут быть заменены только производителем, его агентом по обслуживанию или аналогичным квалифицированным лицом.

DK Lyskilden og/eller driver og/eller eksterne kabler indeholdt i dette armatur må kun udskiftes af producenten eller godkendt service partner eller lignende kvalificeret person.

SK Svetelný zdroj a/alebo predradník a/alebo externý flexibilný kábel obsiahnutý v tomto svietidle môže byť vymenený len výrobcom alebo servisným partnerom alebo inou podobne kvalifikovanou osobou.

SE Luskällan och/eller styrsystemet och/eller den externa kabeln i denna armatur får endast bytas ut av tillverkaren eller en kvalificerad person.

LT Šviesos šaltinis ir/arba valdymo įrenginys ir/arba išorinis lankstus kabelis esantis šiame šviestuve gali būti pakeistas tik gamintojo arba jo aptarnavimo agento ar tai atitinkančio kvalifikuoto asmens.

NO Lyskilden og/eller driveren og/eller den eksterne kabeln i dette armaturet skal bare erstattes av produsenten eller dens service agent eller tilsvarende kvalifisert person.

LV Gaismas avotu un / vai vadības ierīci un / vai ārējo elastīgo kabeli, kas atrodas šajā gaismeklī, drīkst nomainīt tikai ražotājs vai viņa servisa pārstāvis vai līdzīga kvalificēta persona.

CZ Světelný zdroj a/nebo napájecí zdroj (předřadník) a/nebo flexibilní napájecí kabel v tomto svítidle smí vyměňovat pouze výrobce nebo jeho servisní technik nebo obdobně kvalifikovaná osoba.

EE Selles valgustis sisalduva valgusallika ja/või juhtimiseadme ja/või välise painduva kaabli võib välja vahetada ainult tootja, vastav hooldusspetsialist või muu sarnane kvalifitseeritud isik.

HU A lámpatestben található fényforrást és/vagy működtető szerelvényt és/vagy a külső rugalmas kábelt csak a gyártó, a gyártóval szerződött cég vagy megfelelő képesítéssel rendelkező szakember cserélheti ki.

SI Vir svetlobe in / ali napajalni in / ali zunanji prilagodljivi kabel, ki ga vsebuje ta svetilka, lahko zamenja le proizvajalec ali njegov servis ali podobna usposobljena oseba.

PL Źródło światła i/lub zasilacz i/lub zewnętrzny przewód zasilający, który jest w sprawie powinien być wymieniony przez producenta lub jego serwisanta lub kwalifikowany personel.