

Description	System light output(Lm)	Color temperature(K)	Power(W)	Energy Efficiency Class of Light source	kg
WT120C G2 LED19S840 PSU L600 BN	1900	4000	15	D	0.8
WT120C G2 LED27S840 PSU L1200 BN	2700	4000	21	D	1.33
WT120C G2 LED40S840 PSU L1200 BN	4000	4000	29	D	1.33
WT120C G2 LED34S840 PSU L1500 BN	3400	4000	24	D	1.64
WT120C G2 LED60S840 PSU L1500 BN	6000	4000	43	D	1.67
WT120C G2 LED80S840 PSU L1500 BN	8000	4000	57	D	1.73

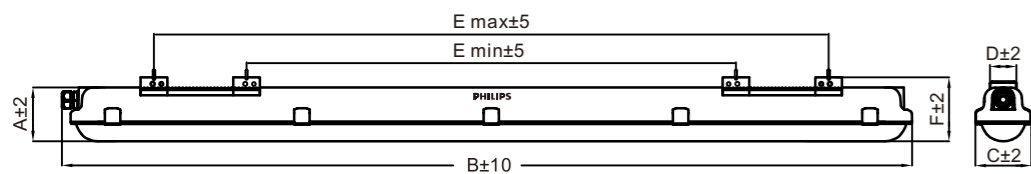

Type	Dimension (mm)						Nr. of clips
	A	B	C	D	E min	E max	
WT120C G2 LED19S840 PSU L600 BN	76	665	80	38	308	512	6
WT120C G2 LED27S840 PSU L1200 BN		1215			538	1062	10
WT120C G2 LED40S840 PSU L1200 BN		1515			838	1362	85
WT120C G2 LED34S840 PSU L1500 BN							
WT120C G2 LED60S840 PSU L1500 BN							
WT120C G2 LED80S840 PSU L1500 BN							

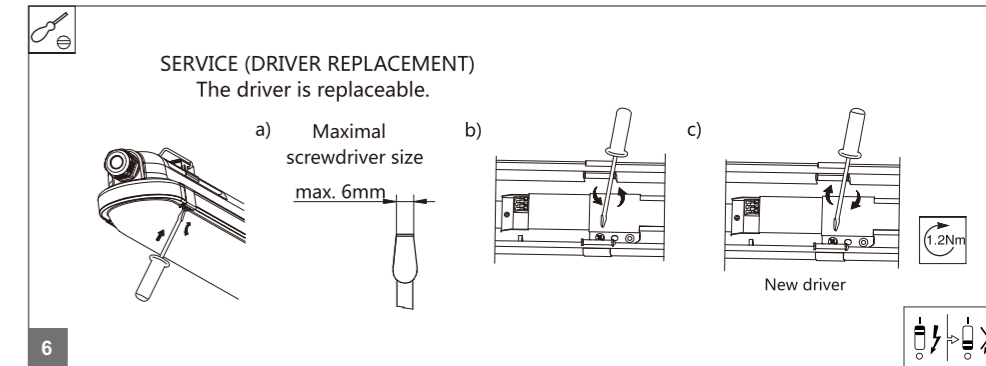
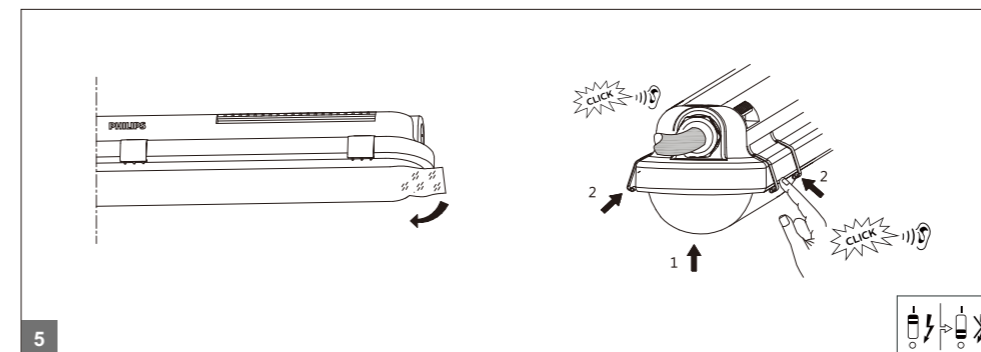
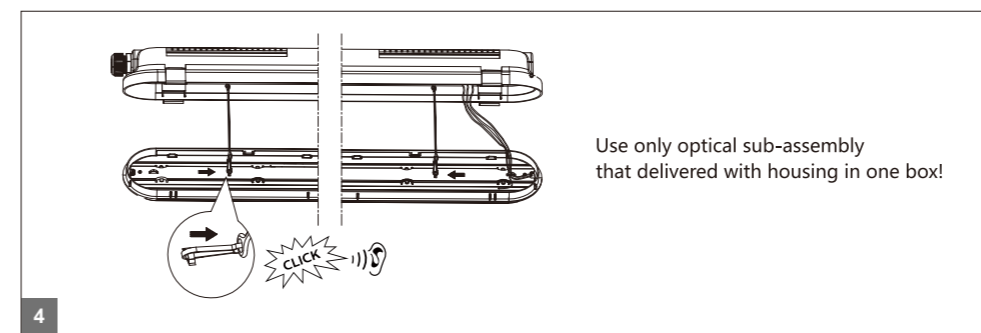
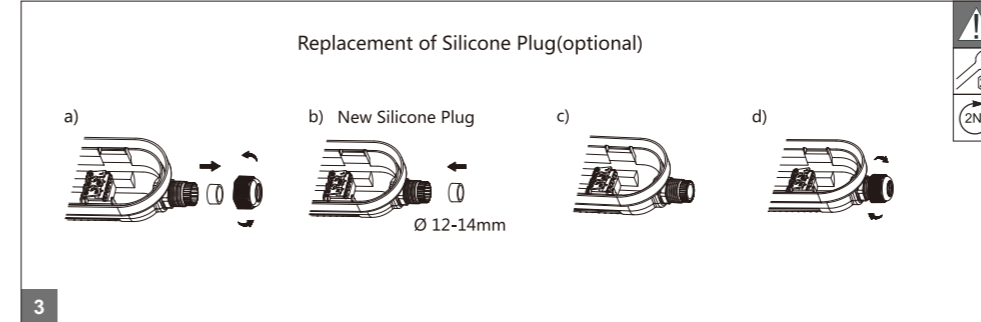
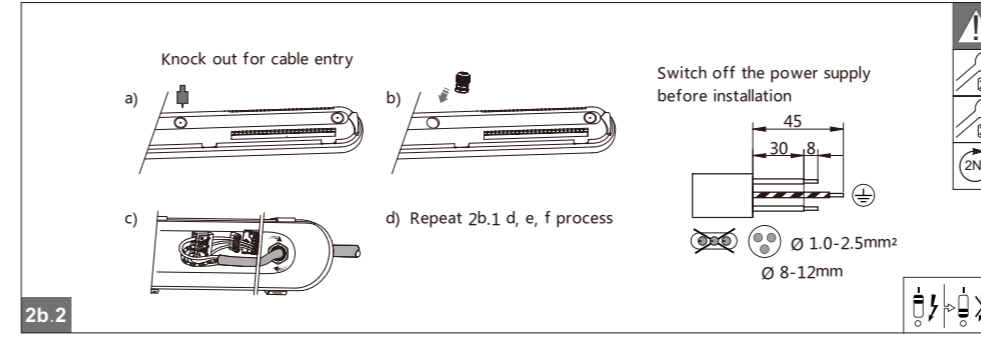
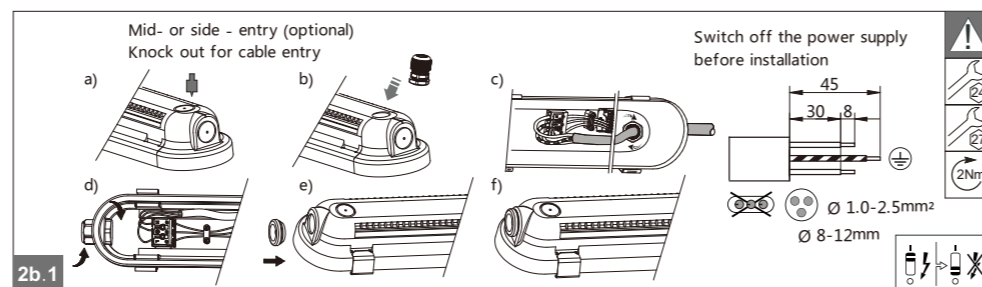
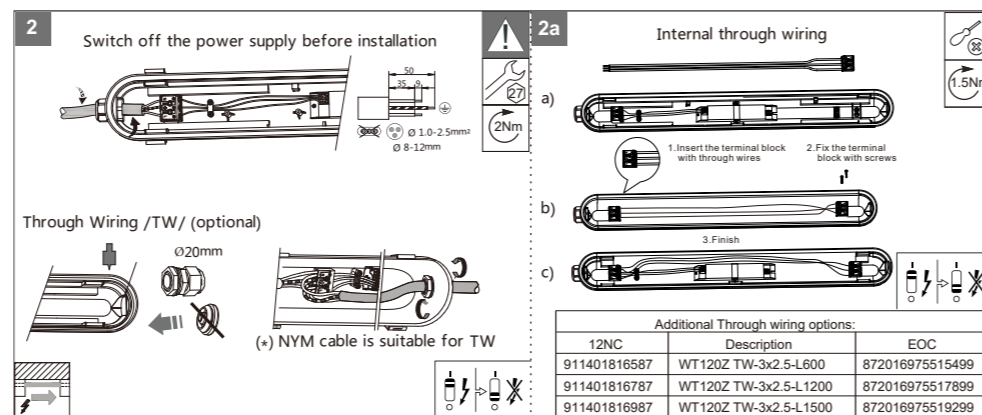
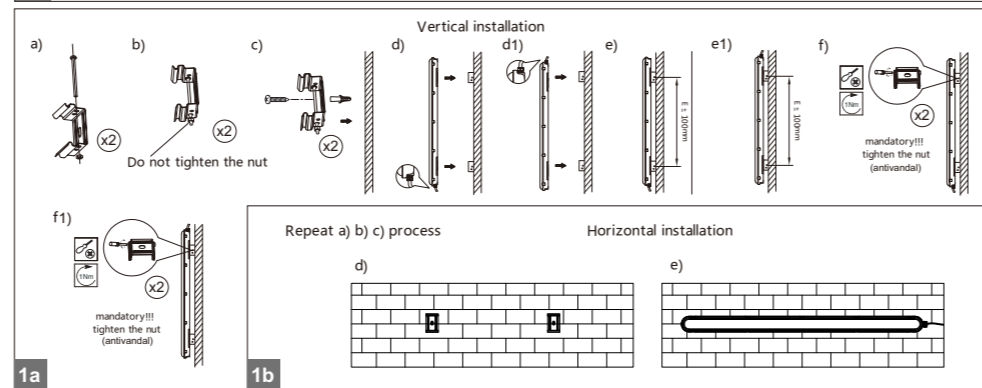
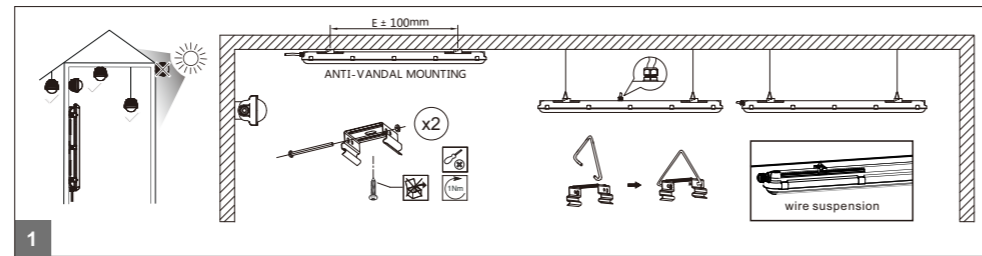

- Do not stare into LED light beam.
- The luminaire shall be installed by a qualified electrician and wired in accordance with the latest IEE electrical regulations or the national requirements.
- The light source contained in this luminaire shall only be replaced by the manufacturer or his service agent or a similar qualified person.
- Above average concentration of sulfur effects the useful lifetime of the product. E.g: Light color changes from white to blue. Typically in chicken & pig farms.
- For use in environments where an accumulation of conductive dust on the luminaire may be expected
- Do not install the luminaire on the location where it is exposed to heavily grease, esp. mineral oil and distillates (petroleum), heavy naphthenic treated with hydrogen.
- This product is not suitable for cold & humid storage areas, especially where obvious temperature gradients are present, such as ventilation opening, door, etc.
- Do not install the luminaire on locations where it is exposed to direct sunlight. UV radiation will damage the material over time resulting in loss of waterproof sealing and IP65 rating.
- Do not install the luminaire on the location where it is exposed to (animal) grease, oil, esp. cooking or mineral oil and distillates (petroleum), heavy naphthenic treated with hydrogen, or swimming pool applications (with chlorine present), or carwash (due to chemicals and/or salt presence).

	LED19S	LED27S	LED40S	LED34S	LED60S	LED80S
Driver I peak [A]	3.58	3.58	14.2	5.16	14.2	15
Driver Tref [µs]	40	40	222	47	222	240
Max. Nr. of connecting products by MCB type						
MCB 16A type B	80	80	36	60	36	31
MCB 10A type B	50	50	22	37	22	19
MCB 16A type C	136	136	60	102	60	52
MCB 10A type C	80	80	37	62	37	32
Max. Nr. of connecting products by through wire cross-section area						
1.0 mm ²	45	33	23	27	16	11
1.5 mm ²	67	49	35	41	23	18
2.5 mm ²	112	82	59	69	39	29

According to MCB type & through wire cross-section area, choose the minimum number to connect products.

© 07/2024 Signify Holding. All rights reserved. This document contains information relating to the product portfolio of Signify which information may be subject to change. No representation or warranty as to the accuracy or completeness of the information included herein is given and any liability for any action in reliance thereon is disclaimed. The information presented in this document is not intended as any commercial offer and does not form part of any quotation or contract. Philips and the Philips Shield Emblem are registered trademarks of Koninklijke Philips N.V.. All other trademarks are owned by Signify Holding or their respective owners.

Signify Holding.
The Netherlands



