

PHILIPS

UV-C disinfection chamber

4-log disinfection in minutes

An excellent combination of unique design and effective surface disinfection, for professional use



Effectiveness of UV-C on COVID-19 confirmed

In a study conducted by the National Emerging Infectious Diseases Laboratories (NEIDL) at Boston University in a laboratory setting, Signify's UV-C light sources irradiating the surface of a material inoculated with SARS-CoV-2 (the virus that causes the COVID-19 disease) with a UV-C irradiance of 0.849 mW/cm² reduced SARS-CoV-2 virus infectivity to below detectable levels in as few as 9 seconds for dried virus and 4 seconds for wet virus.¹

Signify is the leader in UV-C light sources and has been at the forefront of UV technology for more than 35 years. It has a proven track record of innovation in UV-C lighting, which is designed, manufactured and installed in line with the highest safety standards.

¹ Nadia Storm et al, *Rapid and complete inactivation of SARS-CoV-2 by ultraviolet-C irradiation*, 2020.
Report available at <https://www.nature.com/articles/s41598-020-79600-8>. The UV-C irradiance used in this study was 0.849 mW/cm².

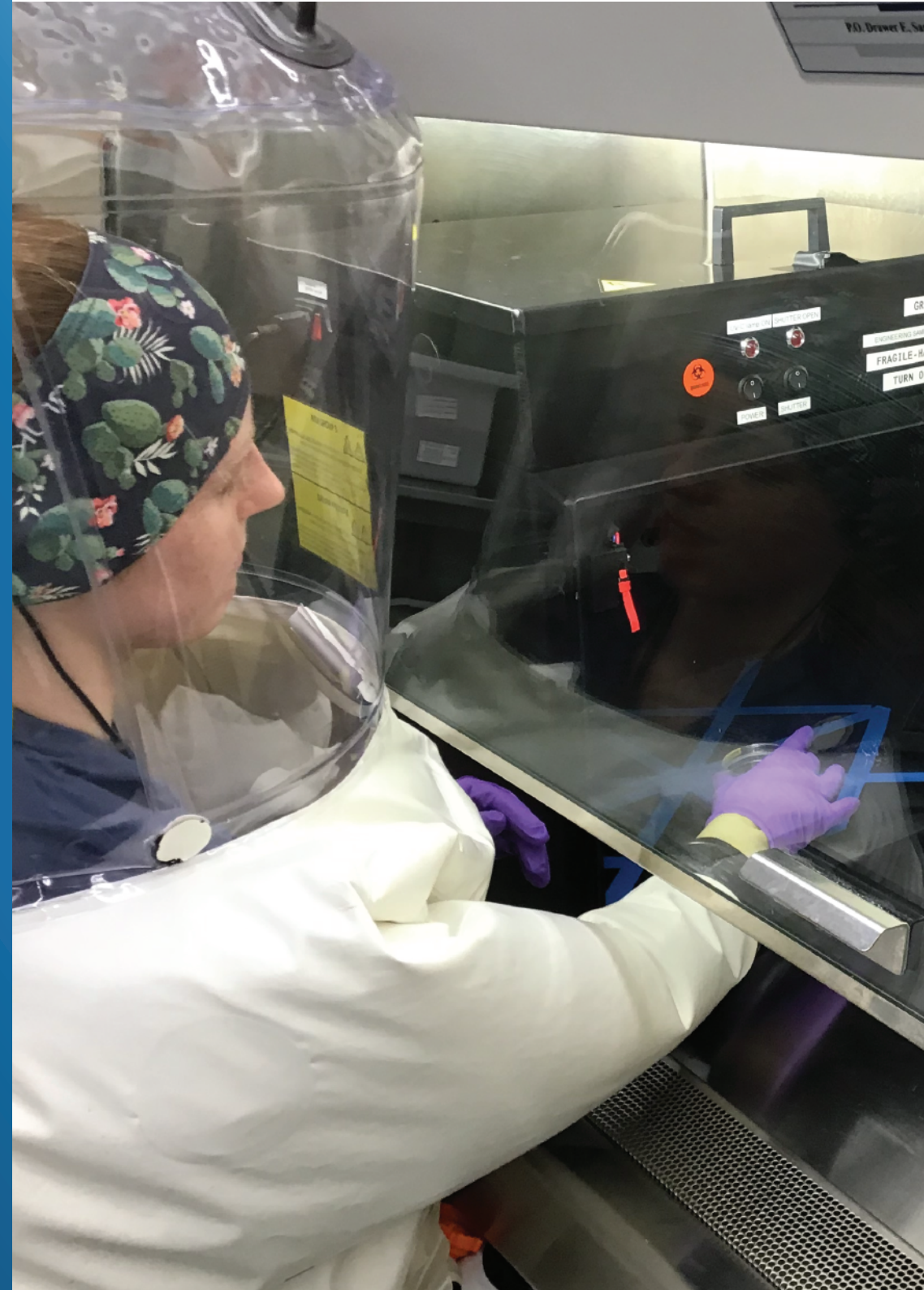

UV-C disinfection chamber

UV-C disinfection chamber is intended to be used for disinfection surfaces of objects other than medical devices. UV-C effectively inactivates many viruses and pathogens on directly irradiated surfaces.¹

The UVC disinfection chamber will be available in two variants, small and medium.

- Small UVCC 100 with height of 510 mm (77-litres)
- Medium UVCC 200 with height of 660mm (112-litres)

The UV-C disinfection chamber design optimises the effectiveness of Philips UV-C lamp (253.7nm) to provide 4-log (99.99%) disinfection with time guidelines and avoid over exposure to the object.

UV-C disinfection chamber is designed for versatile objects surface disinfection. This UV-C product is not approved and/or certified as a medical device.



Effective

- 4-log disinfection

Fast

- Can disinfect surface of the objects in minutes with 4-log (99.99%) disinfection

Environmentally friendly

- Chemical free disinfection, no residuals on object surface.
- No collateral damage to the environment of use.
- Ozone free (Ozone is a poisonous gas; it creates irritation and especially people with respiratory problems such as asthma should not be exposed)

Safety

- The product is fully compliant with the safety standard IEC60335-1: 2010
- * Direct exposure of UV-C is dangerous to living beings, chamber only starts when the door is securely closed, and disinfection cycle is activated
- Auto power off when the chamber is open ensuring no UV-C exposure to user

Robust

- Stainless-Steel chamber with sturdy trays to support heavy items up to 6Kgs
- Easy to use, one touch operation

¹ Fluence (UV Dose) Required to Achieve Incremental Log Inactivation of Bacteria, Protozoa, Viruses and Algae Revised, updated and expanded by Adel Haji Malayeri, Madjid Mohseni, Bill Cairns and James R. Bolton. With earlier contributions by Gabriel Chevretils (2006) and Eric Caron (2006) With peer review by Benoit Barbeau, Harold Wright (1999) and Karl G. Linden.

Features



Prefixed time selector for duration of disinfection. Easy to use, one touch operation.



Optimised window size to maximise UV-C dosage. Blue glow from glass window is a visual indicator for the disinfection cycle in progress.



Two trays for accommodating multiple objects, upper tray is removable to fit bigger objects

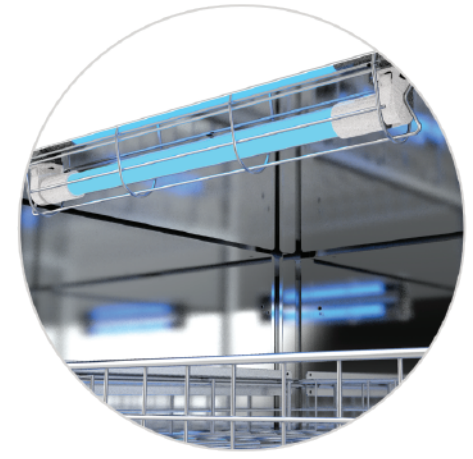

Lamp safety cover, to ensure safety of lamp while accessing trays

Safety



Disinfection starts only when the door is firmly closed. In case of lamp failure, it can be easily detected through the window when lamps are working #







During the disinfection cycle, if the door is accidentally opened by someone the UV-C lamps will automatically turn off, to prevent UV-C exposure.

UVC lamp must be replaced by authorised service centres

Applications

- Pharmacies
- Offices
- Banks
- Hotel
- Schools
- Universities
- Retail
- Hypermarket, supermarkets
- Food courts
- Restaurants
- Industrial kitchens etc
- Fitness centres
- Industries
- Barber shop | Spa
- E-commerce pick up points
- Courier services

Disinfection Time- Medium Size

Objects	Object size	Recommended disinfection time	Remark	Placement
2 Big objects	400mm*350mm*120mm	10 mins*	Minimum 50mm distance to lamp	
1 Small object	150mm*150mm*150mm	3 mins*	Minimum 50mm distance to lamp	
1 Big object	400mm*350mm*320mm	10 mins*	Minimum 50mm distance to lamp	
Multiple small objects	150mm*135mm*120mm	10 mins*	Minimum 50mm (object to objects)	

Material Safety

Degradation can be negligible for inorganic materials such as glass, glass fibres, and metal which are not affected by UV-C exposure¹. For all organic material degradation refer to ASHRAE research project RP-1509 report. The device cannot be used to disinfect the surfaces of medical devices (such as medical devices in a room, surgical masks and/or surgical respirators); The device cannot be used for disinfection of human skin.

¹ Based on study from Kauffman 2011, 2012; Kauffman and Wolf 2012, 2013

Specifications

Tray details

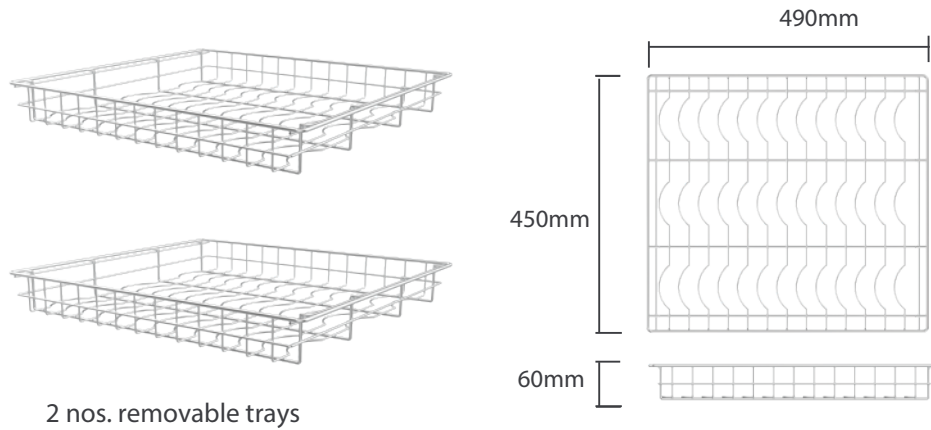

Chamber dimensions



Technical specifications - medium - UVCC 200

S. No	Parameters	Medium - UVCC 200
1	Disinfection effect	4-log disinfection (mJ/cm ²)
2	Input voltage	220-240V, 50/60 Hz
3	Total power	80W
4	UV-C lamp wavelength	253.7nm
5	Time setting	Time set up level 3min/5min/10min/20min
6	Ozone free	Yes
7	Safety start	Yes (power ON when door is closed)
8	Door open protection	Yes (power OFF when door is open)
9	Operating temp	+10°C to +40°C
10	Dimensions	660 x 560 x 590 (in mm)
11	Front door	Tempered Glass (Small glass window)
12	Housing material	Stainless steel/ tempered glass
13	Warranty	1 year



© 2021 Signify Holding. All rights reserved. The information provided herein is subject to change, without notice. Signify does not give any representation or warranty as to the accuracy or completeness of the information included herein and shall not be liable for any action in reliance thereon. The information presented in this document is not intended as any commercial offer and does not form part of any quotation or contract, unless otherwise agreed by Signify.

Philips and the Philips Shield Emblem are registered trademarks of Koninklijke Philips N.V. All other trademarks are owned by Signify Holding or their respective owners.