

PHILIPS  
hue

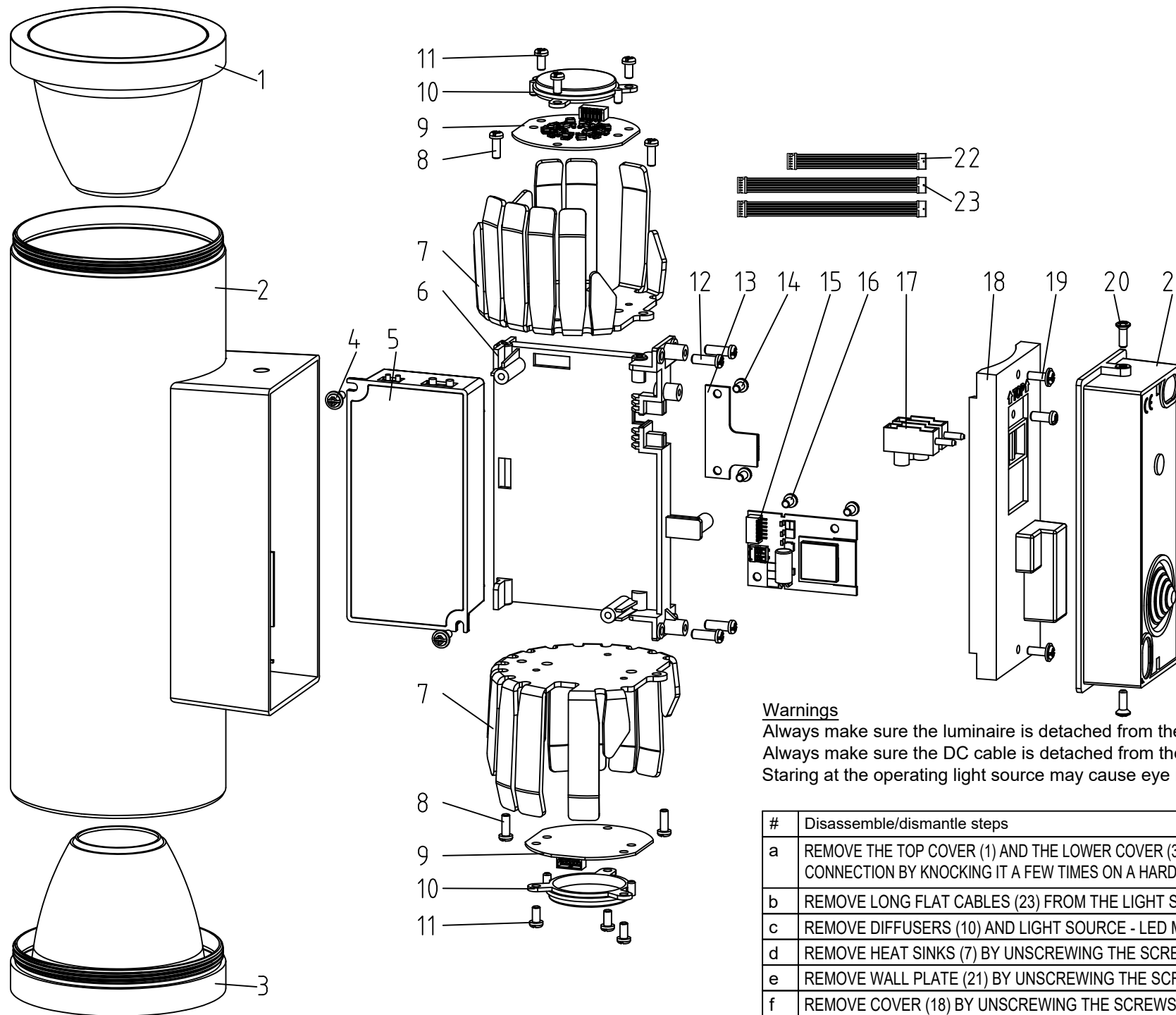

#	COMPONENT	QTY
1	TOP COVER	1
2	TUBE	1
3	LOWER COVER	1
4	SCREW	2
5	CONTROL GEAR - PSU	1
6	BRACKET	1
7	HEAT SINK	2
8	SCREW	4
9	LIGHT SOURCE - LED MODULE	2
10	DIFFUSER	2
11	SCREW	6
12	SCREW	4
13	SPLITTER	1
14	SCREW	2
15	LIGHT SOURCE - HUE CONNECT	1
16	SCREW	2
17	TERMINAL BLOCK	1
18	COVER	1
19	SCREW	3
20	SCREW	2
21	WALL PLATE	1
22	SHORT FLAT CABLE	1
23	LONG FLAT CABLE	2

**Warnings**

Always make sure the luminaire is detached from the mains socket  
 Always make sure the DC cable is detached from the power supply  
 Staring at the operating light source may cause eye injury

#	Disassemble/dismantle steps	Tools needed
a	REMOVE THE TOP COVER (1) AND THE LOWER COVER (3), FIRST BREAK THE GLUE OF THE THREAD CONNECTION BY KNOCKING IT A FEW TIMES ON A HARD SURFACE AND THEN UNSCREW WITH BIG TORQUE	STRAP WRENCH OR CHAIN WRENCH
b	REMOVE LONG FLAT CABLES (23) FROM THE LIGHT SOURCE - LED MODULES (9)	-
c	REMOVE DIFFUSERS (10) AND LIGHT SOURCE - LED MODULES (9) BY UNSCREWING THE SCREWS (11)	CROSS HEAD SCREW DRIVER
d	REMOVE HEAT SINKS (7) BY UNSCREWING THE SCREWS (8)	CROSS HEAD SCREW DRIVER
e	REMOVE WALL PLATE (21) BY UNSCREWING THE SCREWS (20)	CROSS HEAD SCREW DRIVER
f	REMOVE COVER (18) BY UNSCREWING THE SCREWS (19)	CROSS HEAD SCREW DRIVER
g	REMOVE BRACKET (6) FROM THE TUBE (2) BY UNSCREWING THE SCREWS (12)	CROSS HEAD SCREW DRIVER
h	REMOVE THE LIGHT SOURCE - HUE CONNECT (15) BY UNSCREWING THE SCREWS (16)	CROSS HEAD SCREW DRIVER
i	REMOVE WIRES OF THE CONTROL GEAR - PSU (5) FROM THE LIGHT SOURCE - HUE CONNECT (15)	FLATHEAD SCREWDRIVER OR WAGO TOOL #2065
j	REMOVE THE SHORT FLAT CABLE (22) FROM THE LIGHT SOURCE - HUE CONNECT (15)	-
k	REMOVE THE SPLITTER (13) BY UNSCREWING THE SCREWS (14)	CROSS HEAD SCREW DRIVER
l	REMOVE THE CONTROL GEAR - PSU (5) BY UNSCREWING THE SCREWS (4)	CROSS HEAD SCREW DRIVER

SKU	Color	Country
915005976301	Stainless steel	EU

STATUS	DESCRIPTION	DESIGN ID
2021-04-12	Appear Hue WACA EU wall lantern inox 2x8	DOC 12NC
NAME WH	LOCAL PART ID	SH. 1
CHECKED	DATE	SH.

A3-P