

# PHILIPS hue

### Warnings

Always make sure the luminaire is detached from the mains socket  
 Always make sure the DC cable is detached from the power supply  
 Staring at the operating light source may cause eye injury

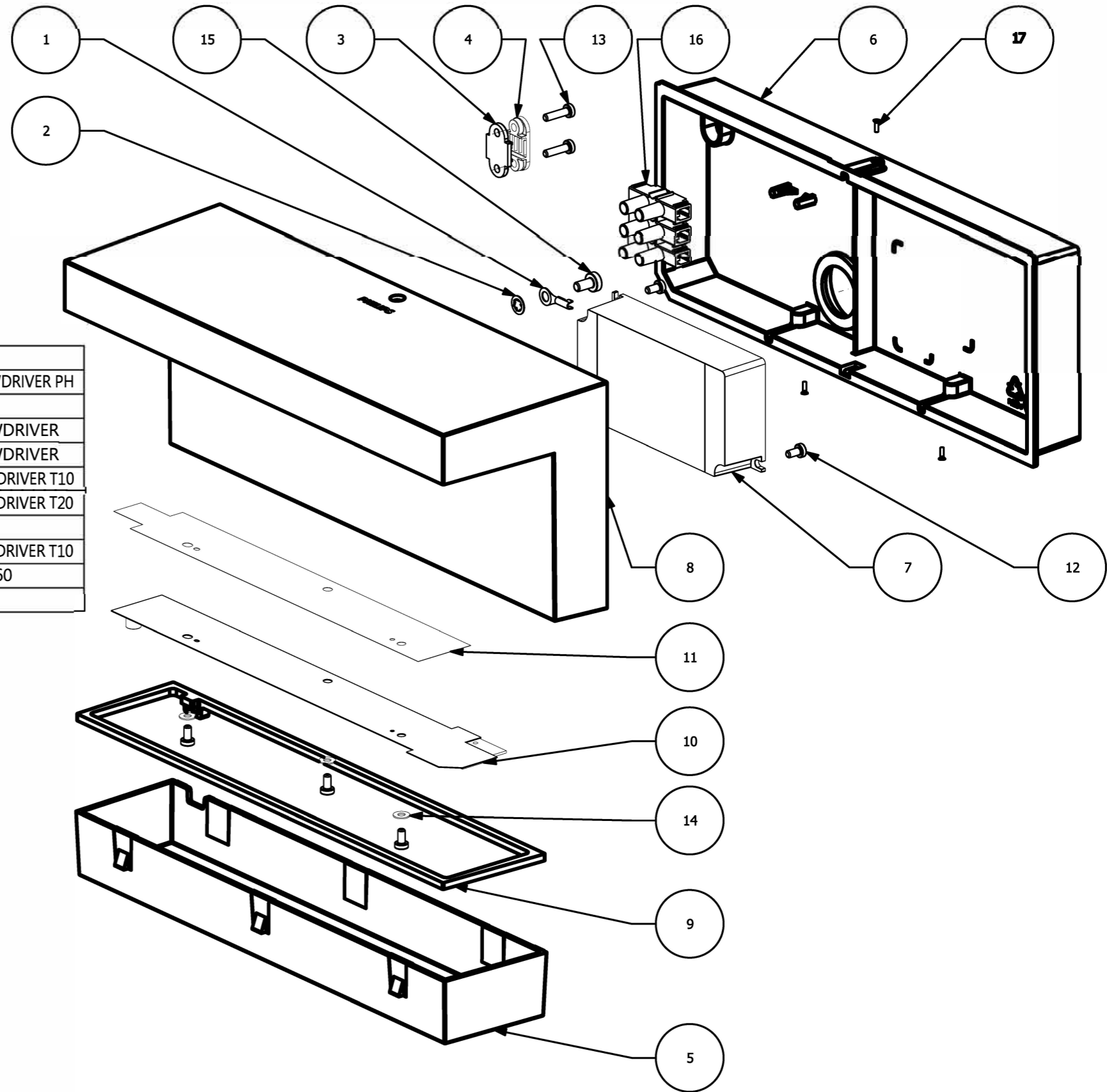

#	Disassemble/dismantle steps	Tools needed
a	Unscrew 3 screws [17] and remove base [6]	CROSSHEAD SCREWDRIVER PH
b	Take out terminal block [20] from base [6]	-
c	Remove wires of the control gear - psu [4] from terminal block [20] by unscrewing	FLATHEAD SCREWDRIVER
d	Remove earthing wire [1] from terminal block [20] by unscrewing	FLATHEAD SCREWDRIVER
e	Unscrew 2 screws [13] and remove 2 pull reliefs [3]+[4]	TORXHEAD SCREW DRIVER T10
f	Unscrew 1 screw [15] and remove ring tongue [1] with wire and washer [2]	TORXHEAD SCREW DRIVER T20
g	Press one side of diffuser [5] and unsnap it from base [8]	-
h	Unscrew 3 screws [12] and remove light source - led module [10],insulation [11] and washers [14]	TORXHEAD SCREW DRIVER T10
i	Unplug wires of control gear-psu [4] from light source-led module [14]	WAGO TOOL #2060
j	Remove gasket [9] from base [8]	-

#	COMPONENT	QTY
1	RING TONGUE WITH EARTHING WIRE	1
2	TOOTH WASHER	1
3	PULL RELIEF	1
4	PULL RELIEF	1
5	DIFFUSER	1
6	BASE	1
7	CONTROL GEAR - PSU	1
8	BASE	1
9	GASKET	1
10	LIGHT SOURCE - LED MODULE	1
11	INSULATION	1
12	SCREW	5
13	SCREW	2
14	WASHER	3
15	SCREW	1
16	TERMINAL BLOCK	1
17	SCREWS	2

SKU	Color	Country
915005841701	black	

STATUS	DESCRIPTION	DESIGN ID	01	2021-06-30
Nyro Hue WACA wall lantern black 1x13.5,Disassembly instruction		DOC 12NC		
NAME	Ku Pa	LOCAL PART ID	SH. 1	A3-L
CHECKED		DATE	2021-06-30	