

OAWC-P – Passive Infrared Wall/Corner Sensor

Catalog#	Prepared by
Project	Date
Comments	Type

Overview

The Passive Infrared Low Voltage Occupancy Sensing Wall/Corner sensor is a motion sensing lighting control that is used for energy savings and convenience.

Features

- Self-Adjusting time delay and sensitivity
- Optional built-in light level sensor
- Optional BAS/HVAC isolated relay
- NEMA WD7 Guide robotic method utilized to verify coverage patterns
- Manual On feature for use with 1 or 2 momentary switches controlling 1 or more Switchpacks (GMD switch)
- Selectable Walk-Through Mode



PIR
Activated



AUTO
Self-Adjusting

Specifications

Technology	Passive Infrared (PIR)
Power Requirements	Input
	0-30 VDC from Greengate Switchpack or Greengate System
	Maximum current needed is 25 mA per sensor
	Output
	Open collector output to switch up to ten Greengate Switchpacks
	Isolated Form C Relay in (-R models) Isolated Form C Relay Ratings: 1A 30 VDC/VAC
Time Delays	Self-Adjusting, 15 seconds/test, 5, 10, 15, 30 minutes
Light Level Sensing (-R Models)	0 to 300 foot-candles
Operating Environment	Temperature: 32°F - 104°F (0°C - 40°C)
	Relative humidity: 20% to 90% Non-condensing For indoor use only
Housing	Durable, injection molded housing. Polycarbonate resin complies with UL 94V-0
Size	4.4" H x 3.4" W x 2" D (112mm x 86.4mm x 50.8mm)
Mounting	Mounts directly to ceiling tile, to a 4" square box and round mud ring or to 4" octagon box
LED Indicators	Red LED for PIR detection
Standards	FCC Compliant cULus Listed RoHS Compliant



Description/Operation

The sensor is designed to detect motion from a heat-emitting source (such as a person entering a room) within its field-of-view and automatically switch lights ON. These sensors have multi-segmented lenses. For units to sense motion, the person must cross between two segments. The distance between segments increases the farther you are from the sensor, so motion has to be larger the farther you are from the unit. PIR sensors are considered line-of-sight sensors, meaning that the sensor must be able to have a direct line-of-sight to the person making the motion. The sensor includes self-adaptive technology that continuously self-adjusts sensitivity and time delay in real-time, maximizing the potential energy savings that are available in the particular application. In Automatic On Mode, the lights turn ON when a person enters the room. In Manual On Mode, the lights are turned ON by activating a momentary switch (model # GMDS-*) that is connected to the sensor. When used with 2 level lighting (-R model only), Bi-level Automatic On can be achieved which allows Zone 1 to come on automatically upon occupancy. Zone 2 does not come on unless the occupant presses the optional momentary switch. When enabled, the daylighting feature (-R models only) prevents lights from turning ON when the room is adequately illuminated by natural light.

Applications

- Offices
- Conference Rooms
- Storage Areas
- Common Areas
- Other Indoor Office
- Aisles/Hallways

Wiring Diagrams

OAWC-P-120W-R, OAWC-P-009-H-R Models

MANUAL MODE OPERATION:

1. SWITCHES ARE REQUIRED TO TURN CORRESPONDING LOADS ON.
2. LOADS TURN OFF WHEN SENSOR TIMES OUT OR WITH SWITCHES.

AUTOMATIC MODE OPERATION:

1. WHEN SENSOR ACTIVATES, BOTH LOADS TURN ON.
2. SWITCHES CAN BE USED TO TURN LOADS ON OR OFF.
3. IF DAYLIGHT SENSOR IS ENABLED AND LIGHT LEVEL IS ABOVE SETPOINT SWITCHPACK CONNECTED TO YELLOW LEAD WILL NOT TURN LOAD ON.

RECOMMENDED WIRE:
18-3 AWG STRANDED WIRE SHIELDED OR NONSHIELDED

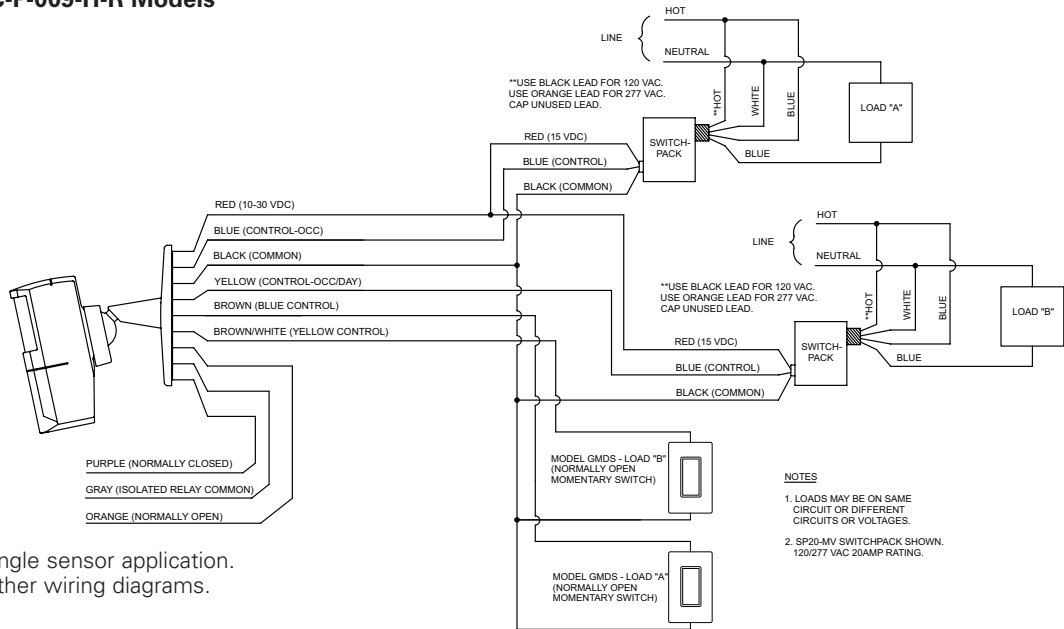

*Wiring diagram for single sensor application.
Visit our website for other wiring diagrams.

Coverage

1200 Sq. ft coverage

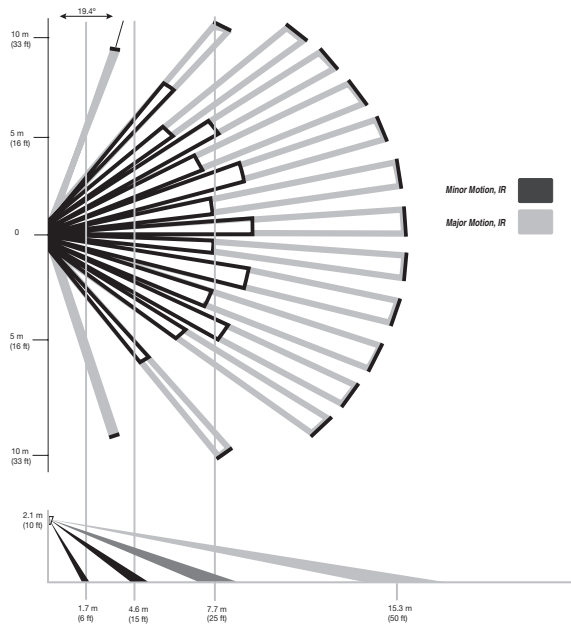

90 linear ft coverage

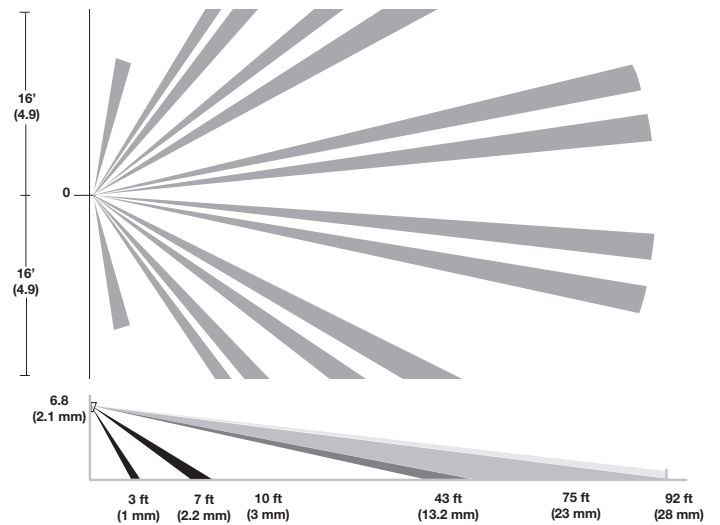

Controls

DIP Switch Legend

DIP Switch	Time Delay		Activation		PIR Sensitivity	Walk-Through Mode	LEDs		Override	Lighting Sweep	Daylighting Mode
	1	2	Power Pack One	Power Pack Two			3	4			
Auto*	▼	▼	Auto ▼	Auto ▼	Full ▼	Disable ▼	Enable ▼	Disable ▼	Disable ▼	Disable ▼	Half ▼
5 Minutes	▼	▲	Manual ▲	Manual ▲	50% ▲	Enable ▲	Disable ▲	Enable ▲	Enable ▲	Enable ▲	Full ▲
15 Minutes	▲	▼									
30 Minutes	▲	▲									

(-R model only)

(-R model only)

*Self-Adjusts to 10 min. user mode

Default =

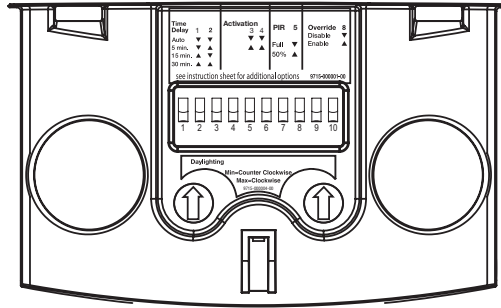

Ordering

Catalog #	Coverage	Field of View	Features
OAWC-P-120W-R	1,200 sq. ft.	Wide Angle, 120°	w/ BAS Relay and Daylight Sensor
OAWC-P-009LH-R	90 linear ft.	180°	w/ BAS Relay and Daylight Sensor
OAWC-P-120W	1,200 sq. ft.	Wide Angle, 120°	
OAWC-P-009LH	90 linear ft.	180°	

Cooper Lighting Solutions
 1121 Highway 74 South
 Peachtree City, GA 30269
 P: 770-486-4800
 www.cooperlighting.com

© 2020 Cooper Lighting Solutions
 All Rights Reserved
 Printed in USA
 Publication No. ACC141016
 November 5, 2014

Cooper Lighting Solutions is a registered trademark.

All other trademarks are property of their respective owners.

