



# Greengate

## Passive Infrared Wall/Corner Mounted Low Voltage Occupancy Sensor

P/N 9850-000143-01



### RoHS

Model # OAWC-P-009L-H  
Model # OAWC-P-009L-H-R

### General Information

- Read all instructions on both sides of this sheet first
- Plan all component locations carefully
- Install in accordance with ALL local codes
- For indoor use only
- For Use with Greengate Switchpacks & Systems Only
- Do not run any Greengate Low Voltage Wiring in the same conduit as power conductors

### Specifications

**Technology:** Passive Infrared (PIR)

**Power Requirements:**

**Input:**

- 10-30 VDC from Greengate Switchpack or Greengate system. Maximum current needed is 25mA per sensor

**Output:**

- Open collector output to switch up to ten Greengate Switchpacks. BAS with Isolated Form C Relay (-R model) Isolated Form C Relay Ratings: 1A 30 VDC/VAC

**Time Delays:** Self-Adjusting, 15 seconds/test(10 min Auto), or Selectable 5, 15, 30 minutes

**Coverage:** 90 sq. ft.

**Light Level Sensing:** 0 to 300 foot-candles (-R model)

**Operating Environment:**

- Temperature: 32° F – 104° F (0° C – 40° C)
- Relative Humidity: up to 90% non-condensing

**Housing:**

- Medium impact injection molded housing Polycarbonate resin complies with UL94V0

**Size:** 4.4" x 3.4" x 2" (112 mm x 86.4 mm x 50.8 mm)

**LED Indicators:** Red indicates PIR detection

### Description

The OAWC-P Wall/Corner Mount Low Voltage Occupancy Sensor is a Passive Infrared (PIR) motion sensing lighting control, used for energy savings and convenience. When motion is detected, the blue wire is electronically connected to the red wire, energizing the relay in the switchpack to turn ON the load. If vacancy is detected, the blue wire is disconnected from the red, causing the relay to open turning OFF the load. The red lead is 10 to 30 VDC supply, the black lead is common, and the blue is the relay control. (-R models: yellow is second relay control)

#### PIR Technology

The sensor's segmented lens divides the field-of-view into sensor zones, and detects the changes in temperature that are created when a person, or part of a person as small as a hand, passes into or out of a sensor zone. The sensor includes self-adaptive technology that continually adjusts to conditions by adjusting sensitivity and time delay in real-time. By adjusting sensitivity and time delay automatically, the sensor is maximizing the potential energy savings that are available in the particular application.

The Daylighting feature (-R model only: yellow control lead only) prevents lights from turning ON when the room is adequately illuminated by natural light.

The Walk-Through feature maximizes energy savings by not leaving the lights ON after a momentary occupancy. The sensor will switch the lights ON when it detects a person entering the area. If the sensor does not continue to detect motion 30 seconds following the initial activation, it will automatically go to a shorter 2 minute time delay.

In Automatic On Mode, the lights turn ON when a person enters the room. In Manual-ON Mode, the lights are turned ON by activating a momentary switch (model # GMDS-\*) that is connected to the sensor. When used with 2 level lighting (-R model only), bi-level Automatic-ON can be achieved which allows Zone 1 to come ON automatically upon occupancy. Zone 2 does not come ON unless the occupant presses the optional momentary switch.

### Coverage

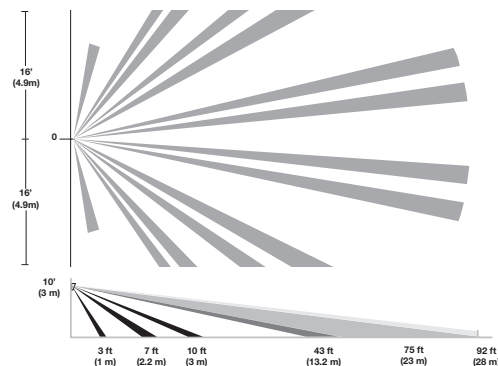

90 linear ft. coverage

### Location

The maximum coverage area may vary somewhat according to room shape and the presence of obstacles. Follow the coverage diagram concerning major and minor motion coverage. The sensor must have a clear view of the area to be controlled. The sensor will not "see" through glass. Mounting height should not exceed 12 feet. Optimum mounting height is 10 feet. To prevent false activation, the sensor should be mounted away from the air supply duct a minimum of 4 to 6 feet. Mounting at fixture height is most effective.

### Installation

The OAWC-P-009L-H can be mounted to the wall, ceiling, junction box, or round fixture with raceway.

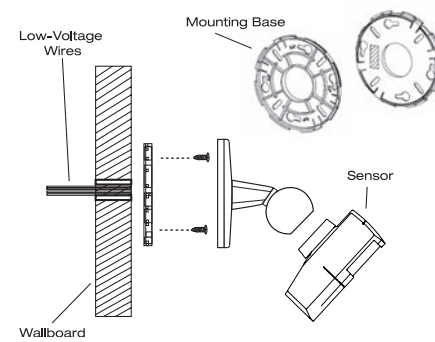

Occupancy Sensor Mounted to Wallboard

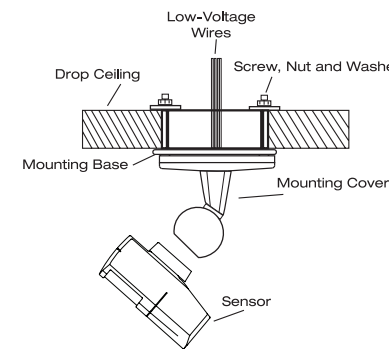

Occupancy Sensor Mounted to Drop Ceiling

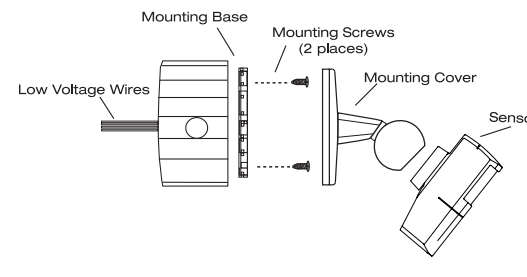

Occupancy Sensor Mounted to Octagon Box

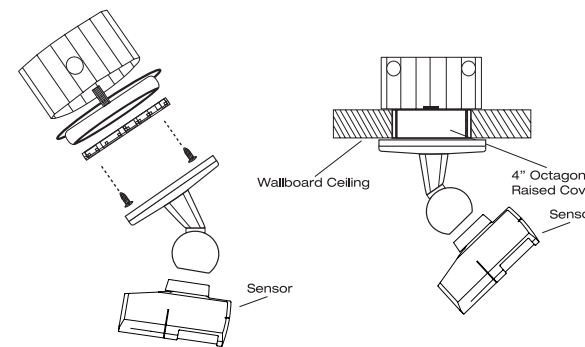

Occupancy Sensor Mounted to Octagon Box with Mud Ring

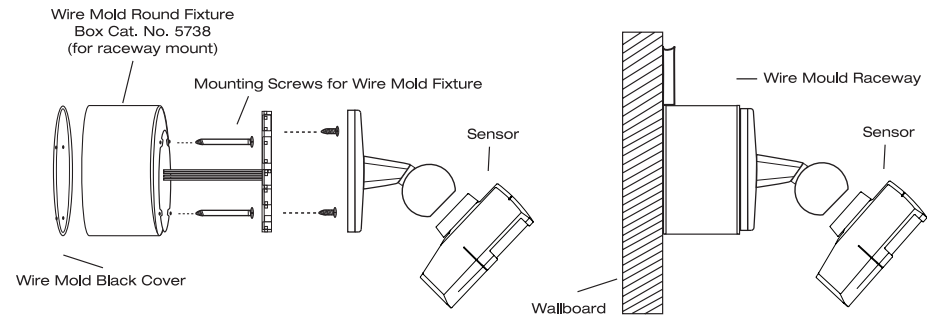

Occupancy Sensor Mounted to Round Fixture with Raceway

### Wiring

**CAUTION:** Before installing or performing any service on a Greengate system, the power **MUST** be turned OFF at the branch circuit breaker. According to NEC 240-83(d), if the branch circuit breaker is used as the main switch for a fluorescent lighting circuit, the circuit breaker should be marked "SWD". All installations should be in compliance with the National Electric Code and all state and local codes.

*NOTE REGARDING COMPACT FLUORESCENT LAMPS:* The life of some compact fluorescent lamps (CFLs) is shortened by frequent automatic or manual switching. Check with CFL and ballast manufacturer to determine the effects of cycling.

1. Make sure power is turned OFF at the branch circuit breaker.
2. Wire units as shown in wiring diagrams per applicable voltage requirements. (Use twist-on wire connectors for all connections) CAP ALL UNUSED WIRE LEADS.
3. Mount unit to wall, ceiling, junction box or round fixture with raceway.
4. Turn power back ON at the branch circuit breaker and wait 2 minutes for the unit to stabilize.
5. Make necessary adjustments. (See Checkout and Adjustments section)

#### One Sensor, One Switchpack

SENSOR WIRE LEAD LEGEND	
Black	(Common)
Red	(10-30 VDC)
Blue	(Control)
Yellow	(Control)
Brown	(Switch-Blue Lead Control)
Brown/White	(Switch-Yellow Lead Control)
Sensor's Isolated Relay	
Orange	(Normally Open)
Gray	(Common)
Purple	(Normally closed)

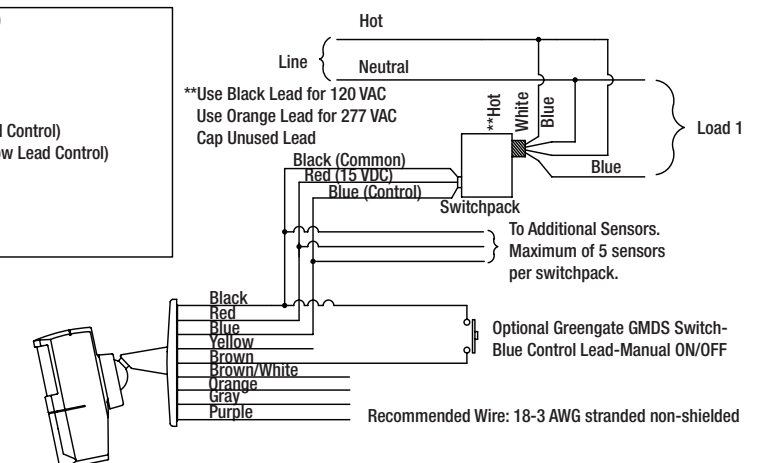

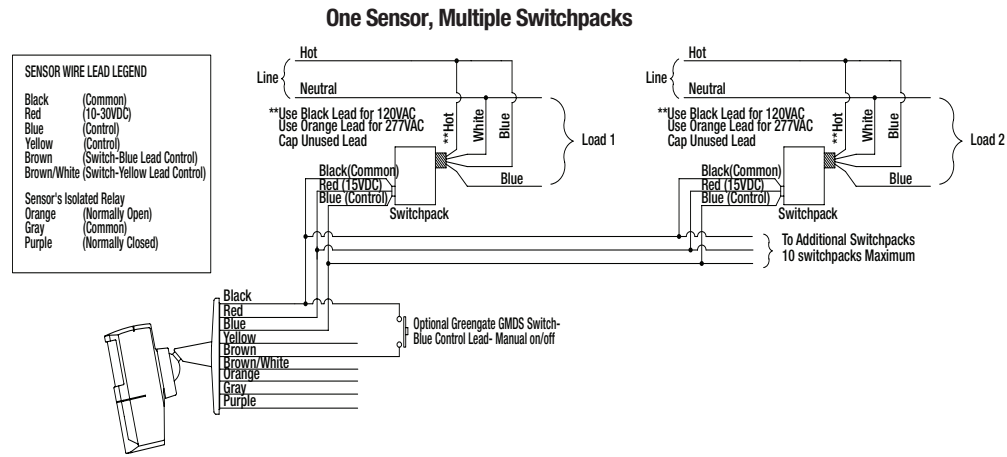

## DIP Switch Settings

DIP Switch	Time Delay		Activation		PIR Sensitivity	Walk-Through Mode	LEDs	Override	Lighting Sweep	Daylighting Mode
	1	2	Power Pack One	Power Pack Two						
	Auto*	Auto	Auto	Auto	Full	Disable	Enable	Disable	Disable	Half
	5 Minutes	Manual	Manual	Manual	50%	Enable	Disable	Enable	Enable	Full
	15 Minutes									
	30 Minutes									

(-R model only)

\*Self-Adjusts to 10 min. user mode  
Default =

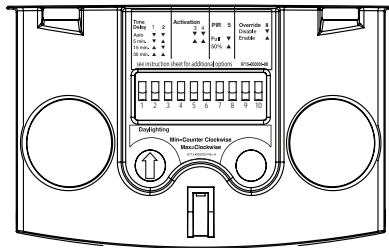

## Checkout and Adjustment

Adjustments should be made with the HVAC system ON. Use only insulated tools to make adjustments.

### Self-Adjust

Sensor is shipped in the Self-Adjust Mode. This applies to time delay and PIR sensitivity. In preparation for the Installer Test, the time delay is set to 15 seconds, after the sensor is installed, powered ON and has stabilized, the unit will time-out 15 seconds after the last motion detected. Coverage and sensitivity can be confirmed by watching the Red (PIR) indicator LED on the front of the sensor, while moving around the room.

1. Walk around the room and monitor LED. LED should only turn ON for one second with each motion. (If LED does not turn ON, go to Installer Adjustments - Sensitivity Adjustments Section)
2. Stand still six to eight feet away from the sensor for five seconds. LED should not turn ON. (If any LED turns ON, go to Installer Adjustments – Sensitivity Adjustment section)
3. Walk outside the room and wait 15 seconds for the lights to turn OFF. (If lights do not turn OFF go to Installer Adjustments Section)
4. Re-enter the room to activate sensor. (If lights do not turn ON go to Troubleshooting Section)
5. The unit will remain in Test Mode for 5 minutes then automatically exit Test Mode and go for 10 min. Time Delay User Mode setting.

**Note:** To place into Test Mode, toggle DIP Switch 10 out of its current position, wait 3 seconds, and then back in to its original position. To force into 10 min User Mode move Dip Switches 1 and 2 down. (If DIP Switches 1 and 2 are already down, toggle DIP Switch 1 out of its current position, wait 3 seconds, and then back to its original position) While in Test Mode, the LEDs will flash once per 1/4 second.

## Installer Adjustments

### Sensitivity Adjustments

#### PIR Sensitivity

1. Stand in different areas of the room and wave your hands.
2. If the Red LED does not turn ON, check for any obstructions.
3. Stand still six to eight feet away from sensor for five seconds. LED should not turn ON.
4. If Red LED turns ON without motion or is constantly ON adjust PIR sensitivity to 50% by moving DIP Switch 5 UP.

#### Field-of-view outside the space

1. Adjust PIR sensitivity to 50% by moving DIP Switch 5 up.

### Daylight Adjustments

If this feature is not needed, leave the light level at maximum (fully CW).

The Daylighting feature (-R model only) prevents the lights from turning ON when the room is adequately illuminated by natural light. If there is enough light in the room regardless of occupancy, the sensor will hold the lights OFF. If there is not enough light in the room, the sensor will allow the lights to turn ON when occupied.

### Full and Half Logic Modes (See DIP Switch legend):

In both Full and Half Logic modes, lights connected to the yellow control lead will not turn ON upon occupancy activation, should the ambient light level exceed the preset foot-candle level.

### After activation:

Full Logic Mode – should the ambient light level exceed the preset foot-candle level, the lights connected to the yellow control lead will turn OFF. The lights will remain OFF, until the ambient light level falls below the set point.

Half Logic Mode – the output state of the yellow control lead will not change with ambient light changes, after occupancy activation. If the amount of natural light available rises above the setpoint, the daylight sensor will not turn the lights OFF while occupancy is being detected.

**Note:** Set the light level when the ambient light is at the level where no artificial light is needed. In order for this feature to function, the yellow control lead must be wired.

1. With the load ON, put the sensor into Test Mode. To place into Test Mode, toggle DIP Switch 10 out of its current position, wait 3 seconds and then back in to its original position.
2. Set DIP Switch 10 to Full or Half Logic Mode.
3. Set the light level to minimum (fully CCW).
4. Leave the room and let the sensor time-out so lights are OFF. Enter the space and lights should remain OFF.
5. Make sure not to block the sensor from the daylight source and adjust the light level potentiometer CW in small increments until the lights are ON. (Pause 5 seconds between each adjustment)
6. Once the lights are ON, the load connected to the sensor will not turn ON if light levels are above the current illumination.

### Time Delay Adjustments

People who remain very still for long periods of time may need a longer Time Delay than the default setting of 10 minutes. As long as Auto is enabled, the sensor will respond to each pair of false-OFFs with no normal OFF in between, by alternately making slight adjustments to either time delay (by 2 minute increments) or sensitivity, so there should be no need for manual adjustment. If manual adjustment is desired, refer to Time Delay settings in DIP Switch legend.

Reset sensor time delay to factory settings by moving DIP Switches 1 and 2 down. (If DIP Switches 1 and 2 are already down, toggle DIP Switch 1 out of its current position, wait 3 seconds, and then back to its original position)

### Automatic Mode

In Automatic ON Mode, the lights turn ON when a person enters the room. If optional momentary low voltage switches are used along with Automatic ON Mode, activating the switch(es) while the load is ON turns the load OFF. When the load is turned OFF manually, as long as the sensor continues to detect occupancy the loads stay OFF. After the time delay expires, the lights stay OFF and the sensor goes back to Automatic ON Mode. For wiring information for the optional momentary low voltage switch(es), please see the wiring section of the installation instructions.

### Manual Mode

In Manual ON Mode, the optional momentary low voltage switch(es) is required to turn the load(s) ON. Once activated the sensor will maintain the lights ON until motion ceases and the time delay expires. While the room is occupied the BAS relay remains active. After the time delay expires, the load(s) will automatically be turned OFF and the switch(es) must be used to turn the load(s) ON unless there is motion detected within the 10 second re-trigger period.

### Lighting Sweep Option

If selected, this DIP Switch option forces an initial 60 second delay upon “power-up” to prevent false activation in buildings with computer control systems.

1. Move DIP Switch 9 UP.

### Override

The Override setting allows the lights to remain ON in the unlikely event of sensor failure.

1. Move DIP Switch 8 UP.

While in Override Mode, the optional low voltage momentary switch(es) will toggle the lighting load(s).

## Troubleshooting

Issue	Possible Causes	Suggestions
<b>Lights Will Not Turn ON automatically</b>	Wall Switch OFF	Turn Wall Switch ON
	If low voltage switch option is used, lights may have been turned-off manually	Press low-voltage switch
	Daylighting Feature Enabled	If all lights are required to turn ON adjust DIP Switch 10 and/or daylight potentiometer
	Power interruption	Check incoming voltage and/or wiring
<b>Lights Will Not Turn ON manually</b>	Daylighting Feature Enabled	If all lights are required adjust DIP Switch 10 and/or daylight potentiometer
	Power interruption	Check incoming voltage and/or wiring
<b>If lights will still not turn ON, set sensor to override mode and call Technical Services at 1-800-553-3879</b>		
<b>Lights Will Not Turn OFF automatically</b>	Override	Make sure sensor is not in Override Mode (DIP Switch 8 up)
	Sensor installed close to an air vent	Sensors should be installed 4 - 6 feet away from any air vent and out of heavy air flow
	Sensor installed close to indirect lighting	Sensors should be mounted away from indirect lighting
	Self-adjust	It may be possible for the unit to have self-adjusted the time delay to a 30 minute delay. If the lights do not turn OFF after 30 minutes follow next step
	30 Minute Delay	Maximum time delay is 30 Minutes. Check DIP Switches to verify DIP Switch settings. If lights do not turn OFF at the set time delay, check next step
	PIR activated by heat source other than occupant	Move DIP Switch 5 UP
<b>Lights Will Not Turn OFF manually</b>	Bypass	Check wiring to make sure sensor or switchpack are not bypassed.
	Wiring	Check Wiring
<b>If lights will still not turn OFF, call Technical Services at 1-800-553-3879</b>		

## Warranties and Limitation of Liability

Please refer to [www.cooperlighting.com](http://www.cooperlighting.com) under the Legal section for our terms and conditions.