

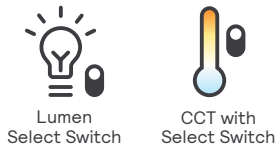

**Lightolier LED Flat Downlight dual select** provides an easy and quick downlight solution without the traditional frame and reflector. Perfect for installation in low plenum and existing shallow space ceilings. The CCT selector (2700K, 3000K, 3500K, 4000K & 5000K) and Lumen selector features make it easy to adjust both features at the time of installation.



Project: \_\_\_\_\_  
 Location: \_\_\_\_\_  
 Cat.No: \_\_\_\_\_  
 Type: \_\_\_\_\_  
 Qty: \_\_\_\_\_  
 Notes: \_\_\_\_\_

### Fixture

example: FD3RSLMZ10SCTUW

Family	Size	Lumens	Dimming	CCT / CRI	Voltage	Finish
<b>FD</b>						<b>W</b>
FD Flat Downlight	3R 3in Round	4 400lm	E TRIAC to 5%	SCT Field Selectable 5CCT options	1 120V	W White (matte)
		SLM Field Selectable (370lm/500lm)	Z10 0-10V	SCT Field Selectable 5CCT options	U UNV	
	4R 4in Round	7 700lm	E TRIAC to 5%	SCT Field Selectable 5CCT options	1 120V	
		SLM Field Selectable (540lm/700lm)	Z10 0-10V	SCT Field Selectable 5CCT options	U UNV	
	5R 5in Round	9 900lm	E TRIAC to 5%	SCT Field Selectable 5CCT options	1 120V	
		SLM Field Selectable (900lm/1100lm)	Z10 0-10V	SCT Field Selectable 5CCT options	U UNV	
	6R 6in Round	11 1100lm	E TRIAC to 5%	SCT Field Selectable 5CCT options	1 120V	
		SLM Field Selectable (900lm/1100lm)	Z10 0-10V	SCT Field Selectable 5CCT options	U UNV	
	8R 8in Round	13 1300lm	E TRIAC to 5%	SCT Field Selectable 5CCT options	1 120V	
		SLM Field Selectable (1100lm/1300lm)	Z10 0-10V	SCT Field Selectable 5CCT options	U UNV	
	3S 3in Square	SLM Field Selectable (370lm/500lm)	Z10 0-10V	SCT Field Selectable 5CCT options	U UNV	
	4S 4in Square	SLM Field Selectable (540lm/700lm)	Z10 0-10V	SCT Field Selectable 5CCT options	U UNV	
	6S 6in Square	SLM Field Selectable (900lm/1100lm)	Z10 0-10V	SCT Field Selectable 5CCT options	U UNV	
	8S 8in Square	SLM Field Selectable (1100lm/1300lm)	Z10 0-10V	SCT Field Selectable 5CCT options	U UNV	

Note: Square downlights not stocked in Canada. Please inquire for price and availability.

SCT Field Selectable 5CCT options are (2700K, 3000K, 3500K, 4000K & 5000K).

### Accessories

DSAEC20 20" Extension Cord	DSFD3RTBK 3" Round Flat Downlight Trim Black	DSFD3STBK 3" Square Flat Downlight Trim Black
DSANCP346 3" 4" 6" Round Plate for new construction	DSFD4RTBK 4" Round Flat Downlight Trim Black	DSFD4STBK 4" Square Flat Downlight Trim Black
DSANCP5 5" Round Plate for new construction	DSFD5RTBK 5" Round Flat Downlight Trim Black	DSFD6STBK 6" Square Flat Downlight Trim Black
DSANCP468 4" 6" 8" Round Plate for new construction	DSFD6RTBK 6" Round Flat Downlight Trim Black	DSFD8STBK 8" Square Flat Downlight Trim Black
DSANCP346 3" 4" 6" Square Plate for new construction	DSFD8RTBK 8" Round Flat Downlight Trim Black	
DSANCP468 4" 6" 8" Square Plate for new construction		

### Features

- Flange:** metal alloy, powder coating in white.
- Lens:** diffuser is used for smooth and diffused light pattern.
- Junction Box:** extruded aluminum and steel.
- Connector:** locking power connection is used to connect J-box and fixture. Standard length of the connection is 14.96in (38cm).
- Ceiling cutout:** installation template is provided.
- Gasket:** foam gasket supplied with fixture.

### Electrical

**Electronic power supply:**  
 RoHS compliant.  
 Isolated driver, Grounding Class 2 Power Unit.  
 Remote power supply can only accommodate one LED module and cannot be shared with other LED module.

**Dimming:**  
 120V versions are compatible with ELV/TRIAC (120V) dimmers.  
 UNV versions are compatible with 0-10V (UNV) dimmers.

### Labels

ETL listed (UL 1598) for wet locations (covered ceiling only). IC rated for direct contact with thermal insulation.  
 AirSeal for minimal air leakage.  
 ENERGY STAR® certified.  
 Title 24 compliant (JA8).

### Warranty

**Lifetime:** Expected lifetime 50,000 hours and backed by a 5-year warranty (visit [signify.com/warranties](http://signify.com/warranties) for details).

# FD Flat Downlight dual select

Round & Square aperture recessed downlight

## Dimensions

Downlight 3" Round

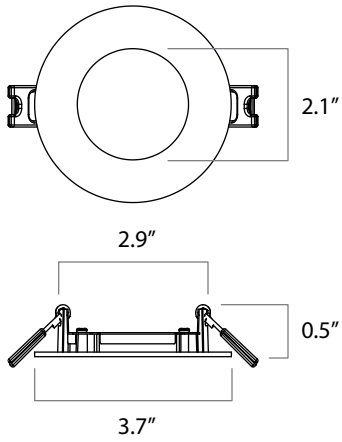

Downlight 3" Square

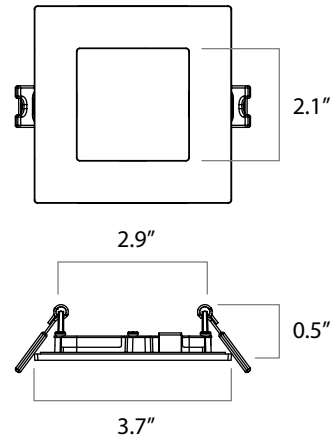

Downlight 4" Round

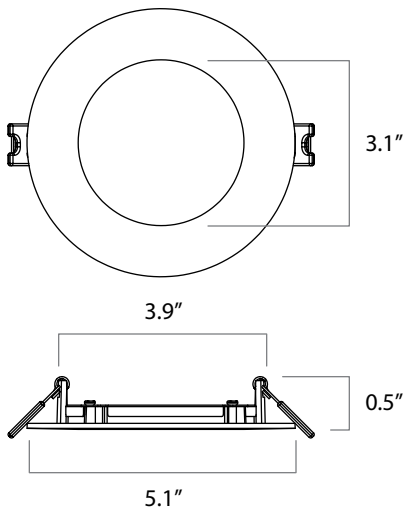

Downlight 4" Square

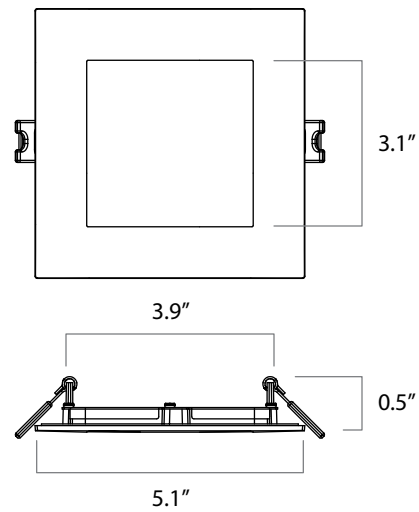

Downlight 5" Round

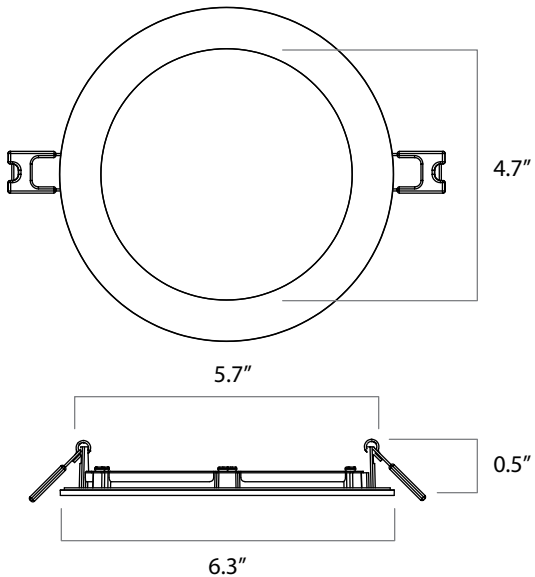

# FD Flat Downlight dual select

## Round & Square aperture recessed downlight

### Dimensions

Downlight 6" Round

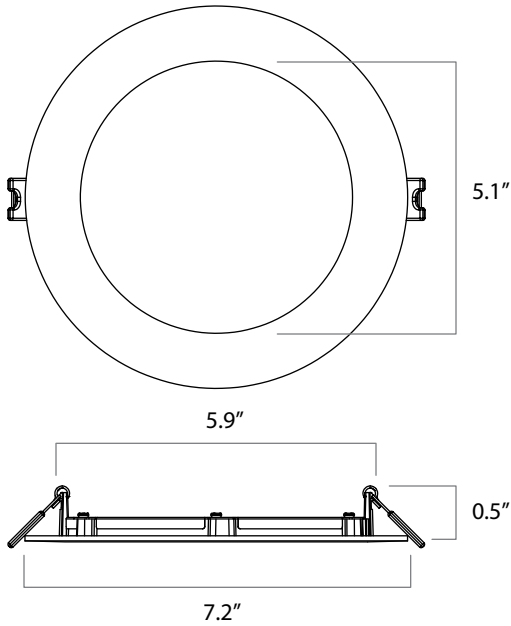

Downlight 6" Square

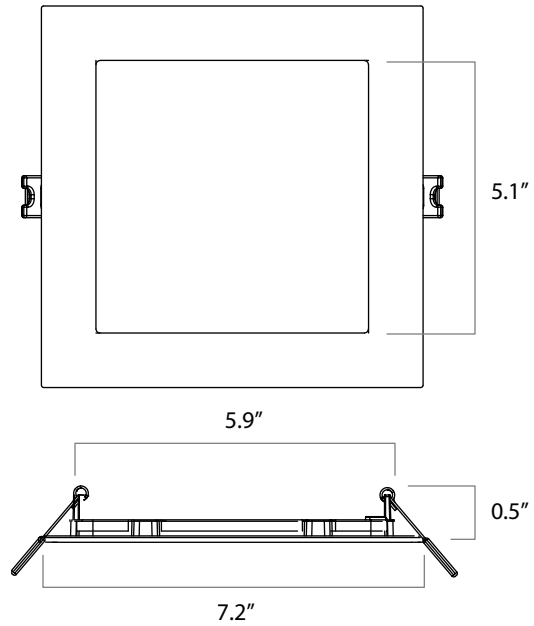

Downlight 8" Round

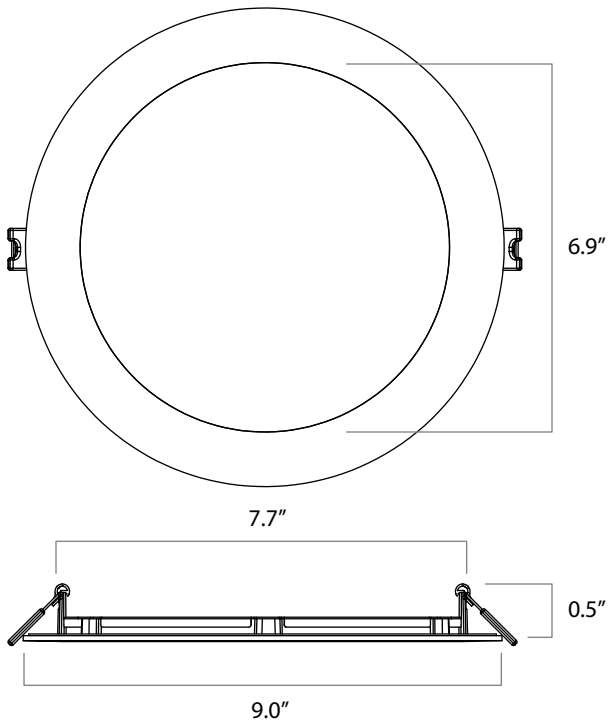

Downlight 8" Square

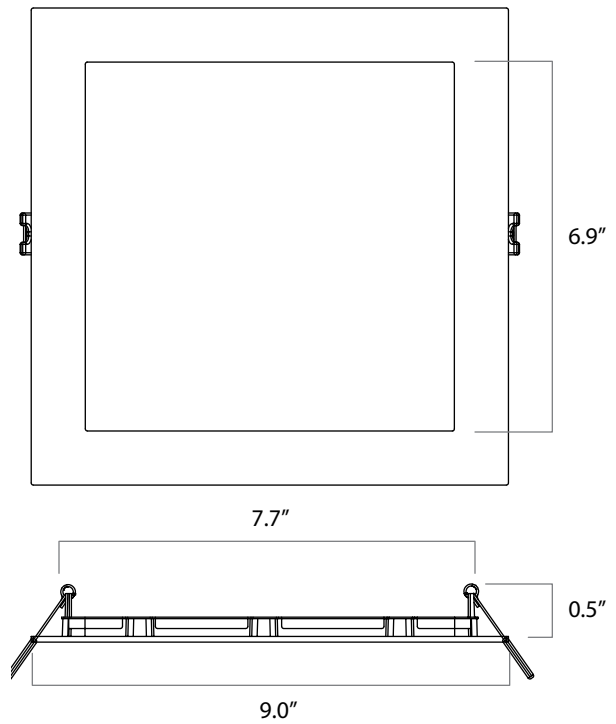

# FD Flat Downlight dual select

## Round & Square aperture recessed downlight

### Components

1. Electrical Box with knockouts
2. 14.96" (0.38m) cord
3. CCT selector
4. Integrated LED Luminaire
5. Spring clip for easy mounting

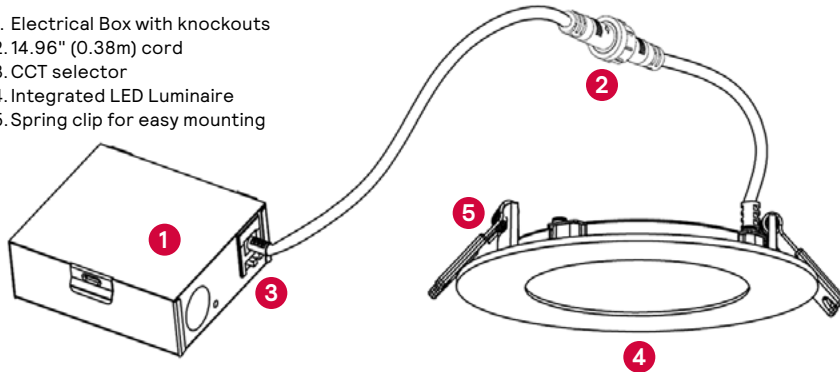

### Junction box

#### J-Box Triac

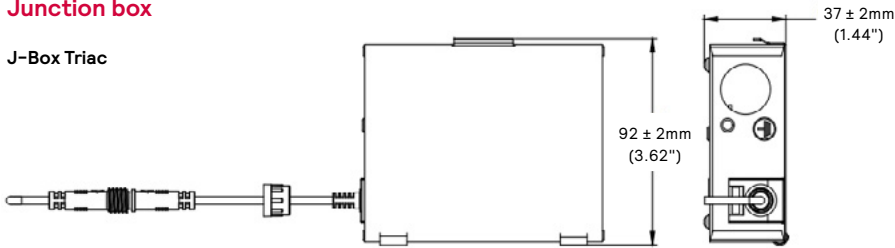

#### J-Box UNV

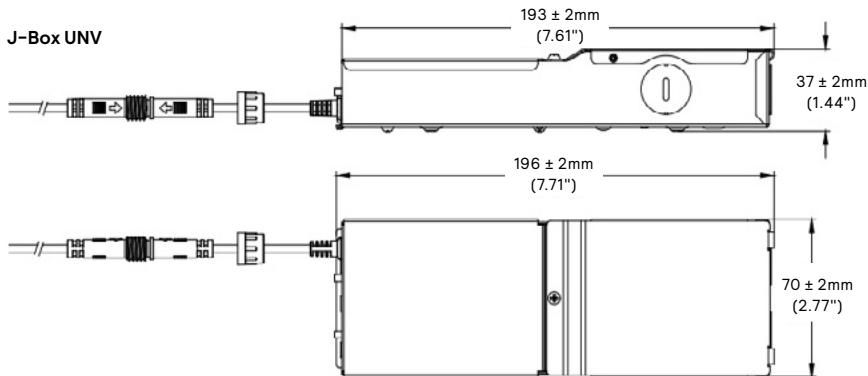

	Lumen Output	Input voltage	Input Freq	Max. Input current	Max. Input power	Max. THD	Power factor	CRI
3" Round 120V	480lm	120V	60Hz	0.20A	8W	20%	0.9	90
3" Round UNV	370lm/500lm	120V - 277V	50/60Hz	0.20A	8W/6W	20%	0.9	90
4" Round 120V	700lm	120V	60Hz	0.25A	11W	20%	0.9	90
4" Round UNV	540lm/700lm	120V - 277V	50/60Hz	0.25A	11W/9W	20%	0.9	90
5" Round 120V	900lm	120V	60Hz	0.30A	13W	20%	0.9	90
5" Round UNV	700lm/900lm	120V - 277V	50/60Hz	0.30A	13W/11W	20%	0.9	90
6" Round 120V	1100lm	120V	60Hz	0.39A	15W	20%	0.9	90
6" Round UNV	900lm/1100lm	120V - 277V	50/60Hz	0.39A	15W/12W	20%	0.9	90
8" Round 120V	1300lm	120V	60Hz	0.41A	18W	20%	0.9	90
8" Round UNV	1100lm/1300lm	120V - 277V	50/60Hz	0.41A	18W/15W	20%	0.9	90
3" Square UNV	370lm/500lm	120V - 277V	50/60Hz	0.20A	8W/6W	20%	0.9	90
4" Square UNV	540lm/700lm	120V - 277V	50/60Hz	0.28A	11W/9W	20%	0.9	90
6" Square UNV	900lm/1100lm	120V - 277V	50/60Hz	0.39A	15W/12W	20%	0.9	90
8" Square UNV	1100lm/1300lm	120V - 277V	50/60Hz	0.41A	18W/15W	20%	0.9	90

\* Restrictions on Hazardous Substances (RoHS) is a European directive (2002/95/EC) designed to limit the content of 6 substances [lead, mercury, cadmium, hexavalent chromium, polybrominated biphenyls (PBB), and polybrominated diphenyl ethers (PBDE)] in electrical and electronic products. For products used in North America compliance to RoHS is voluntary and self-certified.

# FD Flat Downlight dual select

## Round & Square aperture recessed downlight

### FD3RSLMZ10SCTUW • 3" Round, Field Selectable, Field Selectable 5CCT, Universal Voltage, White Finish

Candela Curve

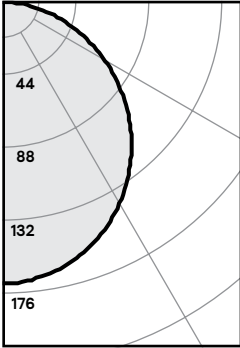

Fixture: **FD3RSLMZ10SCTUW**

Output lumens: 480 lms  
 Input watts: 7.7 W  
 CRI: 90 (min)  
 CCT<sup>1</sup>: 2700K  
 Beam Angle: 110°  
 Spacing Criterion: 1.24

Zonal summary

Zone	Lumens	%Luminaire
0-30	131	27.3%
0-40	214	44.6%
0-60	376	78.3%
0-90	480	100.0%

Angle	Mean CP	Lumens
0	169	
5	167	
10	165	16
15	161	
20	155	46
25	148	
30	139	69
35	130	
40	119	83
45	108	
50	96	85
55	83	
60	70	77
65	57	
70	44	59
75	32	
80	20	35
85	8	
90	0	11

Single unit data

Height to lighted plane	Initial center beam foot-candles	Beam diameter (ft)*
5'	7	6.2'
6'	5	7.4'
7'	3	8.7'
8'	3	9.9'
9'	2	11.2'

\* Beam diameter is where foot-candles drop to 50% of maximum.

Multiple unit data - RCR 2

Spacing on center	Initial center beam foot-candles	Watts per sq. ft.
5'	19.0	0.34
6'	13.0	0.22
7'	9.0	0.16
8'	8.0	0.13
9'	6.0	0.11

38' x 38' x 10' Room, Workplane 2.5' above floor, 80/50/20% Reflectances

**Efficacy: 62.3lm/w**  
 Report<sup>2</sup>: STD220234NB-C

Coefficients of utilization

Ceiling	80%				70%		50%		30%		0%	
	70	50	30	10	50	10	50	10	50	10	0	
Wall	70	50	30	10	50	10	50	10	50	10	0	
RCR	Zonal cavity method - Effective floor reflectance = 20%											
Room Cavity Ratio	0	119	119	119	119	116	116	111	111	106	106	100
1	109	104	99	95	101	94	97	91	93	88	83	83
2	99	90	83	77	88	76	85	75	81	73	69	69
3	90	79	71	64	77	64	74	62	72	61	58	58
4	82	70	61	54	69	54	66	53	64	52	49	49
5	76	63	53	47	61	46	59	46	57	45	43	43
6	70	56	47	41	55	41	53	40	52	40	37	37
7	65	51	42	36	50	36	49	36	47	35	33	33
8	60	47	38	32	46	32	45	32	43	32	29	29
9	56	43	34	29	42	29	41	29	40	28	26	26
10	53	39	31	26	39	26	38	26	37	26	24	24

### FD3SSLMZ10SCTUW • 3" Square, Field Selectable, Field Selectable 5CCT, Universal Voltage, White Finish

Candela Curve

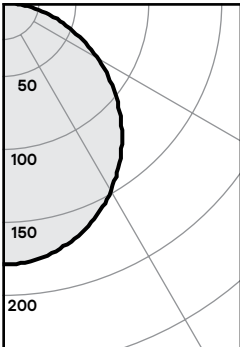

Fixture: **FD3SSLMZ10SCTUW**

Output lumens: 495 lms  
 Input watts: 7.9 W  
 CRI: 90 (min)  
 CCT<sup>1</sup>: 2700K  
 Beam Angle: 109°  
 Spacing Criterion: 1.24

Zonal summary

Zone	Lumens	%Luminaire
0-30	137	27.7%
0-40	223	45.1%
0-60	390	78.8%
0-90	495	100.0%

Angle	Mean CP	Lumens
0	178	
5	177	
10	175	17
15	170	
20	164	48
25	156	
30	147	72
35	137	
40	126	86
45	114	
50	101	88
55	87	
60	74	79
65	60	
70	46	60
75	33	
80	20	35
85	8	
90	0	10

Single unit data

Height to lighted plane	Initial center beam foot-candles	Beam diameter (ft)*
5'	7	6.2'
6'	5	7.4'
7'	4	8.7'
8'	3	9.9'
9'	2	11.2'

\* Beam diameter is where foot-candles drop to 50% of maximum.

Multiple unit data - RCR 2

Spacing on center	Initial center beam foot-candles	Watts per sq. ft.
5'	19.0	0.35
6'	13.0	0.23
7'	9.0	0.16
8'	8.0	0.14
9'	6.0	0.11

38' x 38' x 10' Room, Workplane 2.5' above floor, 80/50/20% Reflectances

**Efficacy: 62.3lm/w**  
 Report<sup>2</sup>: STD220234NB-H

Coefficients of utilization

Ceiling	80%				70%		50%		30%		0%	
	70	50	30	10	50	10	50	10	50	10	0	
Wall	70	50	30	10	50	10	50	10	50	10	0	
RCR	Zonal cavity method - Effective floor reflectance = 20%											
Room Cavity Ratio	0	119	119	119	119	116	116	111	111	106	106	100
1	109	104	99	95	101	94	97	91	93	88	83	83
2	99	90	83	77	88	76	85	75	81	73	69	69
3	90	79	71	64	77	64	74	62	72	61	58	58
4	82	70	61	54	69	54	66	53	64	52	49	49
5	76	63	53	47	61	46	59	46	57	45	43	43
6	70	56	47	41	55	41	53	40	52	40	37	37
7	65	51	42	36	50	36	49	36	47	35	33	33
8	60	47	38	32	46	32	45	32	43	32	29	29
9	56	43	34	29	42	29	41	29	40	28	26	26
10	53	39	31	26	39	26	38	26	37	26	24	24

1. Correlated Color Temperature: within specs as defined in ANSI\_NEMA\_ANSI C78.377-2008: Specifications for the Chromaticity of Solid State Lighting Products.  
 2. Tested using absolute photometry as specified in LM79: IESNA Approved Method for the Electrical and Photometric Measurements of Solid-State Lighting Products.

# FD Flat Downlight dual select

## Round & Square aperture recessed downlight

### FD4RSLMZ10SCTUW • 4" Round, Field Selectable, Field Selectable 5CCT, Universal Voltage, White Finish

Candela Curve

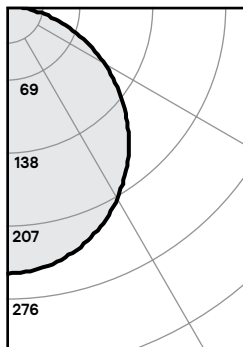

Fixture: **FD4RSLMZ10SCTUW**

Output lumens: 705 lms  
 Input watts: 10.3 W  
 CRI: 90 (min)  
 CCT<sup>1</sup>: 2700K  
 Beam Angle: 110°  
 Spacing Criterion: 1.24

Zonal summary

Zone	Lumens	%Luminaire
0-30	194	27.5%
0-40	316	44.8%
0-60	553	78.4%
0-90	705	100.0%

Angle	Mean CP	Lumens
0	251	
5	249	
10	245	24
15	239	
20	231	68
25	220	
30	208	102
35	193	
40	178	122
45	161	
50	143	125
55	124	
60	105	112
65	86	
70	66	86
75	47	
80	29	51
85	12	
90	0	15

Single unit data

Height to lighted plane	Initial center beam foot-candles	Beam diameter (ft)*
5'	10	6.2'
6'	7	7.4'
7'	5	8.7'
8'	4	9.9'
9'	3	11.2'

\* Beam diameter is where foot-candles drop to 50% of maximum.

Multiple unit data - RCR 2

Spacing on center	Initial center beam foot-candles	Watts per sq. ft.
5'	28.0	0.46
6'	19.0	0.30
7'	13.0	0.21
8'	11.0	0.18
9'	9.0	0.14

38' x 38' x 10' Room, Workplane 2.5' above floor, 80/50/20% Reflectances

**Efficacy:** 68.4 lm/w  
 Report<sup>2</sup>: STD220234NB-D

Coefficients of utilization

Ceiling	80%				70%		50%		30%		0%	
Wall	70	50	30	10	50	10	50	10	50	10	0	
RCR	Zonal cavity method - Effective floor reflectance = 20%											
Room Cavity Ratio	0	119	119	119	119	116	116	111	111	106	106	100
	1	108	104	99	95	101	94	97	91	93	88	83
	2	99	90	83	77	88	77	85	75	81	73	69
	3	90	79	71	64	78	64	75	63	72	62	58
	4	82	70	61	54	69	54	66	53	64	53	50
	5	76	63	54	47	61	47	59	46	57	46	43
	6	70	56	47	41	55	41	54	40	52	40	38
	7	65	51	42	36	50	36	49	36	47	35	33
	8	60	47	38	32	46	32	45	32	43	32	30
	9	56	43	35	29	42	29	41	29	40	29	27
	10	53	40	32	26	39	26	38	26	37	26	24

### FD4SSLMZ10SCTUW • 4" Square, Field Selectable, Field Selectable 5CCT, Universal Voltage, White Finish

Candela Curve

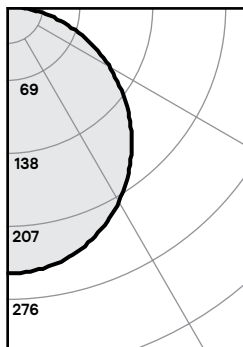

Fixture: **FD4SSLMZ10SCTUW**

Output lumens: 705 lms  
 Input watts: 10.8 W  
 CRI: 90 (min)  
 CCT<sup>1</sup>: 2700K  
 Beam Angle: 110°  
 Spacing Criterion: 1.26

Zonal summary

Zone	Lumens	%Luminaire
0-30	194	27.5%
0-40	316	44.8%
0-60	553	78.4%
0-90	705	100.0%

Angle	Mean CP	Lumens
0	250	
5	249	
10	245	24
15	239	
20	231	68
25	220	
30	208	102
35	193	
40	178	122
45	161	
50	143	125
55	124	
60	105	112
65	86	
70	66	86
75	47	
80	29	51
85	12	
90	0	15

Single unit data

Height to lighted plane	Initial center beam foot-candles	Beam diameter (ft)*
5'	10	6.3'
6'	7	7.6'
7'	5	8.8'
8'	4	10.1'
9'	3	11.3'

\* Beam diameter is where foot-candles drop to 50% of maximum.

Multiple unit data - RCR 2

Spacing on center	Initial center beam foot-candles	Watts per sq. ft.
5'	28.0	0.48
6'	19.0	0.31
7'	13.0	0.22
8'	11.0	0.19
9'	9.0	0.15

38' x 38' x 10' Room, Workplane 2.5' above floor, 80/50/20% Reflectances

**Efficacy:** 65.3 lm/w  
 Report<sup>2</sup>: STD220234NB-I

Coefficients of utilization

Ceiling	80%				70%		50%		30%		0%	
Wall	70	50	30	10	50	10	50	10	50	10	0	
RCR	Zonal cavity method - Effective floor reflectance = 20%											
Room Cavity Ratio	0	119	119	119	119	116	116	111	111	106	106	100
	1	108	104	99	95	101	94	97	91	93	88	83
	2	99	90	83	77	88	77	85	75	81	73	69
	3	90	79	71	64	78	64	75	63	72	62	58
	4	82	70	61	54	69	54	66	53	64	53	50
	5	76	63	54	47	61	47	59	46	57	46	43
	6	70	56	47	41	55	41	54	40	52	40	38
	7	65	51	42	36	50	36	49	36	47	35	33
	8	60	47	38	32	46	32	45	32	43	32	30
	9	56	43	35	29	42	29	41	29	40	29	27
	10	53	40	32	26	39	26	38	26	37	26	24

1. Correlated Color Temperature: within specs as defined in ANSI\_NEMA\_ANSI C78.377-2008: Specifications for the Chromaticity of Solid State Lighting Products.  
 2. Tested using absolute photometry as specified in LM79: IESNA Approved Method for the Electrical and Photometric Measurements of Solid-State Lighting Products.

# FD Flat Downlight dual select

## Round & Square aperture recessed downlight

### FD5RSLMZ10SCTUW • 5" Round, Field Selectable, Field Selectable 5CCT, Universal Voltage, White Finish

Candela Curve

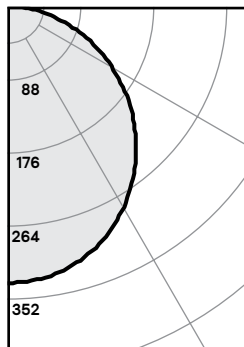

Fixture: **FD5RSLMZ10SCTUW**

Output lumens: 924 lms  
 Input watts: 12.3 W  
 CRI: 90 (min)  
 CCT<sup>1</sup>: 2700K  
 Beam Angle: 110°  
 Spacing Criterion: 1.24

Zonal summary

Zone	Lumens	%Luminaire
0-30	254	27.5%
0-40	414	44.8%
0-60	725	78.5%
0-90	924	100.0%

Angle	Mean CP	Lumens
0	329	
5	327	
10	322	31
15	314	
20	302	89
25	289	
30	272	134
35	253	
40	232	160
45	210	
50	186	164
55	162	
60	137	147
65	111	
70	86	113
75	62	
80	39	68
85	17	
90	0	21

Single unit data

Height to lighted plane	Initial center beam foot-candles	Beam diameter (ft)*
5'	13	6.2'
6'	9	7.4'
7'	7	8.7'
8'	5	9.9'
9'	4	11.2'

\* Beam diameter is where foot-candles drop to 50% of maximum.

Multiple unit data - RCR 2

Spacing on center	Initial center beam foot-candles	Watts per sq. ft.
5'	37.0	0.55
6'	24.0	0.36
7'	17.0	0.26
8'	14.0	0.21
9'	12.0	0.17

38' x 38' x 10' Room, Workplane 2.5' above floor, 80/50/20% Reflectances

Efficacy: **75.1lm/w**  
 Report<sup>2</sup>: STD220234NB-D

Coefficients of utilization

Ceiling	80%				70%		50%		30%		0%	
Wall	70	50	30	10	50	10	50	10	50	10	0	
RCR	Zonal cavity method - Effective floor reflectance = 20%											
Room Cavity Ratio	0	119	119	119	119	116	116	111	111	106	106	100
1	109	104	99	95	101	94	97	91	93	88	83	83
2	99	90	83	78	88	77	85	75	81	73	69	69
3	90	79	71	64	78	64	75	63	72	62	58	58
4	82	70	61	54	69	54	66	53	64	53	50	50
5	76	63	54	47	62	47	59	46	57	46	43	43
6	70	56	47	41	55	41	54	40	52	40	38	38
7	65	51	42	36	50	36	49	36	47	35	33	33
8	60	47	38	32	46	32	45	32	43	32	30	30
9	56	43	35	29	42	29	41	29	40	29	27	27
10	53	40	32	26	39	26	38	26	37	26	24	24

1. Correlated Color Temperature: within specs as defined in ANSI\_NEMA\_ANSI C78.377-2008: Specifications for the Chromaticity of Solid State Lighting Products.  
 2. Tested using absolute photometry as specified in LM79: IESNA Approved Method for the Electrical and Photometric Measurements of Solid-State Lighting Products.

# FD Flat Downlight dual select

## Round & Square aperture recessed downlight

### FD6RSLMZ10SCTUW • 6" Round, Field Selectable, Field Selectable 5CCT, Universal Voltage, White Finish

Candela Curve

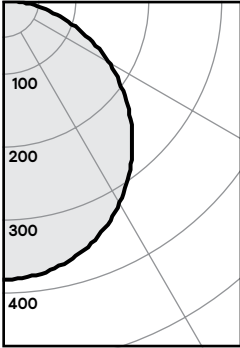

Fixture: **FD6RSLMZ10SCTUW**

Output lumens: 1071 lms  
 Input watts: 13.7 W  
 CRI: 90 (min)  
 CCT<sup>1</sup>: 2700K  
 Beam Angle: 110°  
 Spacing Criterion: 1.26

Zonal summary

Zone	Lumens	%Luminaire
0-30	294	27.5%
0-40	479	44.7%
0-60	839	78.3%
0-90	1071	100.0%

Angle	Mean CP	Lumens
0	380	
5	379	
10	374	36
15	365	
20	353	103
25	337	
30	319	155
35	297	
40	274	185
45	249	
50	222	190
55	194	
60	165	170
65	135	
70	105	130
75	76	
80	49	78
85	23	
90	3	24

Single unit data

Height to lighted plane	Initial center beam foot-candles	Beam diameter (ft)*
5'	15	6.3'
6'	11	7.6'
7'	8	8.8'
8'	6	10.1'
9'	5	11.3'

\* Beam diameter is where foot-candles drop to 50% of maximum.

Multiple unit data - RCR 2

Spacing on center	Initial center beam foot-candles	Watts per sq. ft.
5'	43.0	0.61
6'	28.0	0.40
7'	20.0	0.28
8'	17.0	0.24
9'	14.0	0.19

38' x 38' x 10' Room, Workplane 2.5' above floor, 80/50/20% Reflectances

Efficacy: **78.2lm/w**  
 Report<sup>2</sup>: STD220234NB-F

Coefficients of utilization

Ceiling	80%				70%		50%		30%		0%	
	70	50	30	10	50	10	50	10	50	10	0	
Wall	70	50	30	10	50	10	50	10	50	10	0	
RCR	Zonal cavity method - Effective floor reflectance = 20%											
Room Cavity Ratio	0	119	119	119	119	116	116	111	111	106	106	100
	1	109	104	99	95	101	94	97	91	93	88	83
	2	99	90	83	77	88	77	85	75	81	73	69
	3	90	79	71	64	78	64	75	63	72	61	58
	4	82	70	61	54	69	54	66	53	64	53	50
	5	76	63	54	47	62	47	59	46	57	46	43
	6	70	56	47	41	55	41	54	40	52	40	38
	7	65	51	42	36	50	36	49	36	47	35	33
	8	60	47	38	32	46	32	45	32	43	32	30
	9	56	43	35	29	42	29	41	29	40	29	27
	10	53	40	32	26	39	26	38	26	37	26	24

### FD6SSLMZ10SCTUW • 6" Square, Field Selectable, Field Selectable 5CCT, Universal Voltage, White Finish

Candela Curve

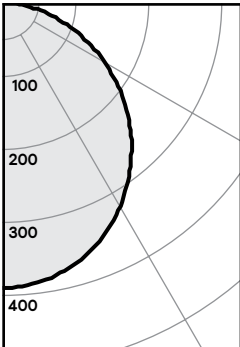

Fixture: **FD6SSLMZ10SCTUW**

Output lumens: 1080 lms  
 Input watts: 14.6 W  
 CRI: 90 (min)  
 CCT<sup>1</sup>: 2700K  
 Beam Angle: 110°  
 Spacing Criterion: 1.24

Zonal summary

Zone	Lumens	%Luminaire
0-30	299	27.7%
0-40	487	45.1%
0-60	851	78.8%
0-90	1080	100.0%

Angle	Mean CP	Lumens
0	388	
5	386	
10	380	37
15	370	
20	357	105
25	340	
30	320	157
35	297	
40	272	188
45	246	
50	218	192
55	188	
60	158	172
65	128	
70	98	130
75	69	
80	42	77
85	18	
90	2	23

Single unit data

Height to lighted plane	Initial center beam foot-candles	Beam diameter (ft)*
5'	16	6.2'
6'	11	7.4'
7'	8	8.7'
8'	6	9.9'
9'	5	11.2'

\* Beam diameter is where foot-candles drop to 50% of maximum.

Multiple unit data - RCR 2

Spacing on center	Initial center beam foot-candles	Watts per sq. ft.
5'	36.0	0.65
6'	24.0	0.42
7'	17.0	0.30
8'	14.0	0.25
9'	11.0	0.20

38' x 38' x 10' Room, Workplane 2.5' above floor, 80/50/20% Reflectances

Efficacy: **74.0lm/w**  
 Report<sup>2</sup>: STD220234NB-J

Coefficients of utilization

Ceiling	80%				70%		50%		30%		0%	
	70	50	30	10	50	10	50	10	50	10	0	
Wall	70	50	30	10	50	10	50	10	50	10	0	
RCR	Zonal cavity method - Effective floor reflectance = 20%											
Room Cavity Ratio	0	119	119	119	119	116	116	111	111	106	106	100
	1	109	104	99	96	102	94	97	91	93	88	83
	2	99	90	84	78	89	77	85	75	82	73	69
	3	90	79	71	65	78	64	75	63	72	62	58
	4	82	70	61	55	69	54	66	54	64	53	50
	5	76	63	54	47	62	47	60	46	58	46	43
	6	70	57	48	41	56	41	54	41	52	40	38
	7	65	51	43	36	51	36	49	36	48	36	33
	8	60	47	38	32	46	32	45	32	44	32	30
	9	56	43	35	29	42	29	41	29	40	29	27
	10	53	40	32	27	39	26	38	26	37	26	24

1. Correlated Color Temperature: within specs as defined in ANSI\_NEMA\_ANSI C78.377-2008: Specifications for the Chromaticity of Solid State Lighting Products.  
 2. Tested using absolute photometry as specified in LM79: IESNA Approved Method for the Electrical and Photometric Measurements of Solid-State Lighting Products.



# FD Flat Downlight dual select

## Round & Square aperture recessed downlight

### FD8RSLMZ10SCTUW • 8" Round, Field Selectable, Field Selectable 5CCT, Universal Voltage, White Finish

#### Candela Curve

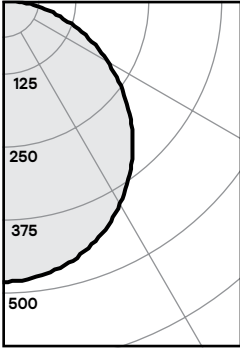

Fixture: **FD8RSLMZ10SCTUW**

Output lumens: 1354 lms  
 Input watts: 17.4 W  
 CRI: 90 (min)  
 CCT<sup>1</sup>: 2700K  
 Beam Angle: 110°  
 Spacing Criterion: 1.24

#### Zonal summary

Zone	Lumens	%Luminaire
0-30	369	27.3%
0-40	602	44.5%
0-60	1056	78.0%
0-90	1354	100.0%

Angle	Mean CP	Lumens
0	478	
5	475	
10	468	45
15	456	
20	440	129
25	420	
30	396	195
35	369	
40	339	233
45	307	
50	273	239
55	237	
60	201	215
65	164	
70	127	166
75	92	
80	58	100
85	27	
90	3	32

#### Single unit data

Height to lighted plane	Initial center beam foot-candles	Beam diameter (ft)*
5'	19	6.2'
6'	13	7.4'
7'	10	8.7'
8'	7	9.9'
9'	6	11.2'

\* Beam diameter is where foot-candles drop to 50% of maximum.

#### Multiple unit data - RCR 2

Spacing on center	Initial center beam foot-candles	Watts per sq. ft.
5'	54.0	0.77
6'	35.0	0.51
7'	25.0	0.36
8'	21.0	0.30
9'	17.0	0.24

38' x 38' x 10' Room, Workplane 2.5' above floor, 80/50/20% Reflectances

**Efficacy: 68.4 lm/w**  
 Report<sup>2</sup>: STD220234NB-G

#### Coefficients of utilization

Ceiling	80%				70%		50%		30%		0%	
	70	50	30	10	50	10	50	10	50	10	0	
Wall												
RCR	Zonal cavity method - Effective floor reflectance = 20%											
Room Cavity Ratio	0	119	119	119	119	116	116	111	111	106	106	100
	1	108	104	99	95	101	94	97	91	93	88	83
	2	99	90	83	77	88	76	85	75	81	73	69
	3	90	79	71	64	77	64	74	62	72	61	58
	4	82	70	61	54	69	54	66	53	64	52	49
	5	76	63	53	47	61	46	59	46	57	45	43
	6	70	56	47	41	55	41	53	40	52	40	37
	7	65	51	42	36	50	36	49	36	47	35	33
	8	60	47	38	32	46	32	45	32	43	32	29
	9	56	43	34	29	42	29	41	29	40	28	26
	10	53	39	31	26	39	26	38	26	37	26	24

### FD8SSLMZ10SCTUW • 8" Square, Field Selectable, Field Selectable 5CCT, Universal Voltage, White Finish

#### Candela Curve

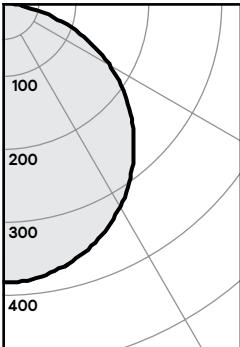

Fixture: **FD8SSLMZ10SCTUW**

Output lumens: 1416 lms  
 Input watts: 17.3 W  
 CRI: 90 (min)  
 CCT<sup>1</sup>: 2700K  
 Beam Angle: 111°  
 Spacing Criterion: 1.26

#### Zonal summary

Zone	Lumens	%Luminaire
0-30	387	27.3%
0-40	632	44.6%
0-60	1110	78.4%
0-90	1416	100.0%

Angle	Mean CP	Lumens
0	498	
5	496	
10	489	47
15	478	
20	463	135
25	443	
30	420	205
35	393	
40	362	245
45	328	
50	292	252
55	255	
60	216	226
65	176	
70	137	172
75	99	
80	62	102
85	28	
90	2	30

#### Single unit data

Height to lighted plane	Initial center beam foot-candles	Beam diameter (ft)*
5'	20	6.3'
6'	14	7.6'
7'	10	8.8'
8'	8	10.1'
9'	6	11.3'

\* Beam diameter is where foot-candles drop to 50% of maximum.

#### Multiple unit data - RCR 2

Spacing on center	Initial center beam foot-candles	Watts per sq. ft.
5'	56.0	0.77
6'	37.0	0.50
7'	27.0	0.36
8'	22.0	0.30
9'	18.0	0.24

38' x 38' x 10' Room, Workplane 2.5' above floor, 80/50/20% Reflectances

**Efficacy: 81.8 lm/w**  
 Report<sup>2</sup>: STD220234NB-K

#### Coefficients of utilization

Ceiling	80%				70%		50%		30%		0%	
	70	50	30	10	50	10	50	10	50	10	0	
Wall												
RCR	Zonal cavity method - Effective floor reflectance = 20%											
Room Cavity Ratio	0	119	119	119	119	116	116	111	111	106	106	100
	1	109	104	99	95	101	94	97	91	93	88	83
	2	99	90	83	78	88	77	85	75	82	73	69
	3	90	79	71	64	78	64	75	63	72	62	58
	4	82	70	61	54	69	54	66	53	64	53	50
	5	76	63	54	47	62	47	59	46	57	46	43
	6	70	56	47	41	55	41	54	40	52	40	38
	7	65	51	42	36	50	36	49	36	47	35	33
	8	60	47	38	32	46	32	45	32	43	32	30
	9	56	43	35	29	42	29	41	29	40	29	27
	10	53	40	32	26	39	26	38	26	37	26	24

1. Correlated Color Temperature: within specs as defined in ANSI\_NEMA\_ANSI C78.377-2008: Specifications for the Chromaticity of Solid State Lighting Products.  
 2. Tested using absolute photometry as specified in LM79: IESNA Approved Method for the Electrical and Photometric Measurements of Solid-State Lighting Products.

