

Installation Instructions for the Sure-Lites SRP and SRM LED Remotes

WARNING

Risk of Fire/Electric Shock

If not qualified, consult an electrician.

WARNING

Risk of Electric Shock

Disconnect power at fuse or circuit breaker before installing or servicing.

Important Safeguards

WHEN USING ELECTRICAL EQUIPMENT, BASIC SAFETY PRECAUTIONS SHOULD ALWAYS BE OBSERVED INCLUDING THE FOLLOWING.

1. READ AND FOLLOW ALL SAFETY INSTRUCTIONS
2. Do not use in hazardous locations, or near gas or electric heaters.
3. Do not let power supply cords touch hot surfaces.
4. Use caution when working with batteries. Battery acid can cause burns to skin and eyes. If acid is spilled on skin or in eyes, flush acid with fresh water and contact a physician immediately.
5. Do not use this equipment for other than the intended use.
6. Installation is to be performed only by qualified personnel.
7. Install in accordance with National Electric Code and local regulatory agency requirements.
8. The use of accessory equipment not recommended by the manufacturer may cause an unsafe condition.
9. Equipment should be mounted in locations and at heights where it will not readily be subjected to tampering by unauthorized personnel.
10. DO NOT EXCEED TOTAL OUTPUT RATING of source power equipment.
11. SAVE THESE INSTRUCTIONS

INSTALLATION

1. Turn off any power supply to source unit equipment. Disconnect battery.
2. Determine wire gage needed using the wire length calculation below. Run wires from source unit equipment to remote junction box. The SRP and SRM remote lights are designed to run at any DC voltage between 4.8 and 12VDC, with any polarity.
3. The SRP and SRM remote lights are weatherproof, and intended for indoor or outdoor mounting. For indoor use, the products can be mounted to a 4" round or octagon

junction box. For interior and exterior use, the products are intended to be mounted to a 4" round weather proof junction box.

4. To insure a weatherproof seal, apply a bead of silicone caulk around the base of the canopy where it attaches to the junction box.
5. Connect the wires from the unit equipment to the wires on the remote head. The SRP and SRM remote heads employ circuitry so they can be wired without regard for polarity.
6. Connect the canopy to the junction box using user supplied screws.
7. Reconnect the battery on the source unit equipment, and reapply power.
8. Energize the lamps by either removing power from the source unit equipment, or pressing the test button on the unit equipment.
9. Aim the heads by loosening the adjustment screws, and then re-tightening after the proper aim is attained. Do not adjust the head by loosening the thread of the knuckle to the canopy. This could allow water to enter the junction box in wet locations. See Figure 1.

Figure 1

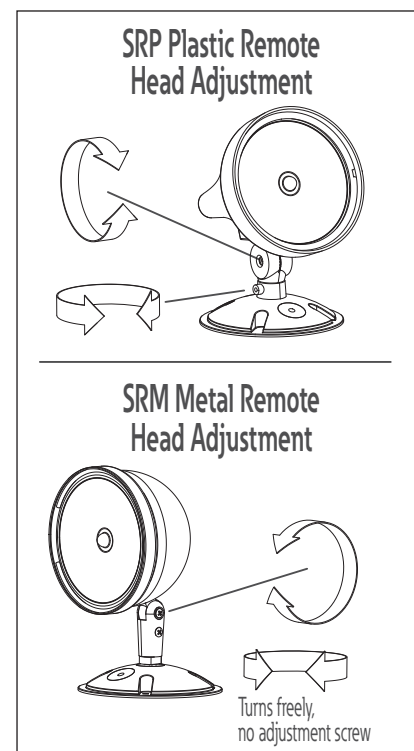

Installation Instructions for SRP and SRM LED Remotes

OPERATION

Depress the test switch on the source unit equipment. The LED heads will light.

MAINTENANCE

None required.

CALCULATING MAXIMUM WIRE LENGTH TO REMOTES

The Sure-Lites LED remotes use a constant current driver that can accept any voltage from 4.8 to 12VDC. This means that the Sure-Lites LED remote will not dim over distance like a standard remote, until the total length of the circuit is too great, and the remote will not light at all. However, the standard voltage drop calculations for remotes will not work and a different calculation must be used.

Models	Heads	Max Mounting Height
SRP13, SRM13	One 1.25W head	19 Ft.
SRP25D, SRM25D	Two 1.25W heads	14 Ft.
SRP25, SRM25	One 2.5W head	28 Ft.
SRP50D, SRM50D	Two 2.5W heads	21 Ft.
SRP30, SRM30	One 5W head	32 Ft.
SRP60D, SRM60D	Two 5W heads	24 Ft.

4.8V Battery	1.25 watt head	Maximum circuit distance per head (ft.)			
		1	2	3	4
	10 Gage (0.001Ω/ft)	600	300	200	150
	12 Gage (0.0015Ω/ft)	400	200	133	100
	14 Gage (0.0025Ω/ft)	240	120	80	60
	18 Gage (0.006Ω/ft)	100	50	33	25
2.5 watt head	Maximum circuit distance per head (ft.)				
	1	2	3	4	
	10 Gage (0.001Ω/ft)	429	214	143	107
	12 Gage (0.0015Ω/ft)	286	143	95	71
	14 Gage (0.0025Ω/ft)	171	86	57	43
	18 Gage (0.006Ω/ft)	71	36	24	18
5 watt head	Maximum circuit distance per head (ft.)				
	1	2	3	4	
	10 Gage (0.001Ω/ft)	429	214	143	107
	12 Gage (0.0015Ω/ft)	286	143	95	71
	14 Gage (0.0025Ω/ft)	171	86	57	43
	18 Gage (0.006Ω/ft)	71	36	24	18

6V Battery	1.25 watt head	Maximum circuit distance per head (ft.)			
		1	2	3	4
	10 Gage (0.001Ω/ft)	1300	650	433	325
	12 Gage (0.0015Ω/ft)	867	434	289	217
	14 Gage (0.0025Ω/ft)	520	260	173	130
	18 Gage (0.006Ω/ft)	216	108	72	54
2.5 watt head	Maximum circuit distance per head (ft.)				
	1	2	3	4	
	10 Gage (0.001Ω/ft)	930	465	310	233
	12 Gage (0.0015Ω/ft)	620	310	207	155
	14 Gage (0.0025Ω/ft)	372	186	124	93
	18 Gage (0.006Ω/ft)	155	78	52	39
5 watt head	Maximum circuit distance per head (ft.)				
	1	2	3	4	
	10 Gage (0.001Ω/ft)	930	465	310	233
	12 Gage (0.0015Ω/ft)	620	310	207	155
	14 Gage (0.0025Ω/ft)	372	186	124	93
	18 Gage (0.006Ω/ft)	155	78	52	39

12V Battery	1.25 watt head	Maximum circuit distance per head (ft.)			
		1	2	3	4
	10 Gage (0.001Ω/ft)	11800	5900	3933	2950
	12 Gage (0.0015Ω/ft)	7866	3933	2622	1967
	14 Gage (0.0025Ω/ft)	4720	2360	1573	1180
	18 Gage (0.006Ω/ft)	1966	983	655	492
2.5 watt head	Maximum circuit distance per head (ft.)				
	1	2	3	4	
	10 Gage (0.001Ω/ft)	8400	4200	2800	2100
	12 Gage (0.0015Ω/ft)	5600	2800	1867	1400
	14 Gage (0.0025Ω/ft)	3360	1680	1120	840
	18 Gage (0.006Ω/ft)	1400	700	467	350
5 watt head	Maximum circuit distance per head (ft.)				
	1	2	3	4	
	10 Gage (0.001Ω/ft)	8400	4200	2800	2100
	12 Gage (0.0015Ω/ft)	5600	2800	1867	1400
	14 Gage (0.0025Ω/ft)	3360	1680	1120	840
	18 Gage (0.006Ω/ft)	1400	700	467	350

The calculation is dependent on the battery voltage, the number and type of heads, the wire gage, and the distance of the farthest head on the circuit. Here are the charts to use for that calculation:

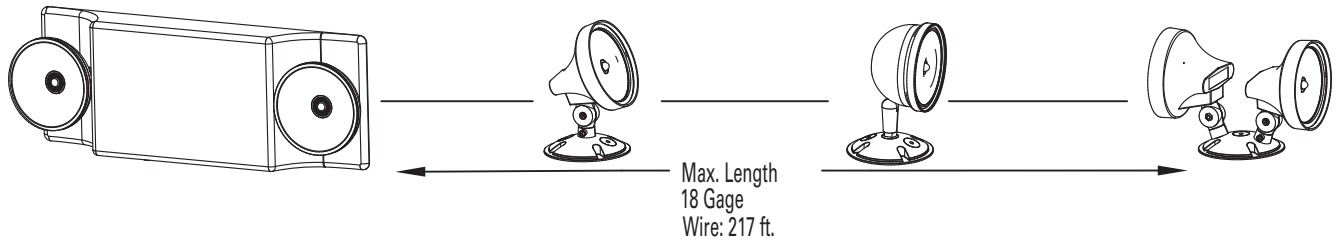

For example, if you had four 1.1 watt heads supplied by 12 gage wire connected to a 6V battery powered emergency light, you could put all four on one circuit, and the total length could only be 217 feet.

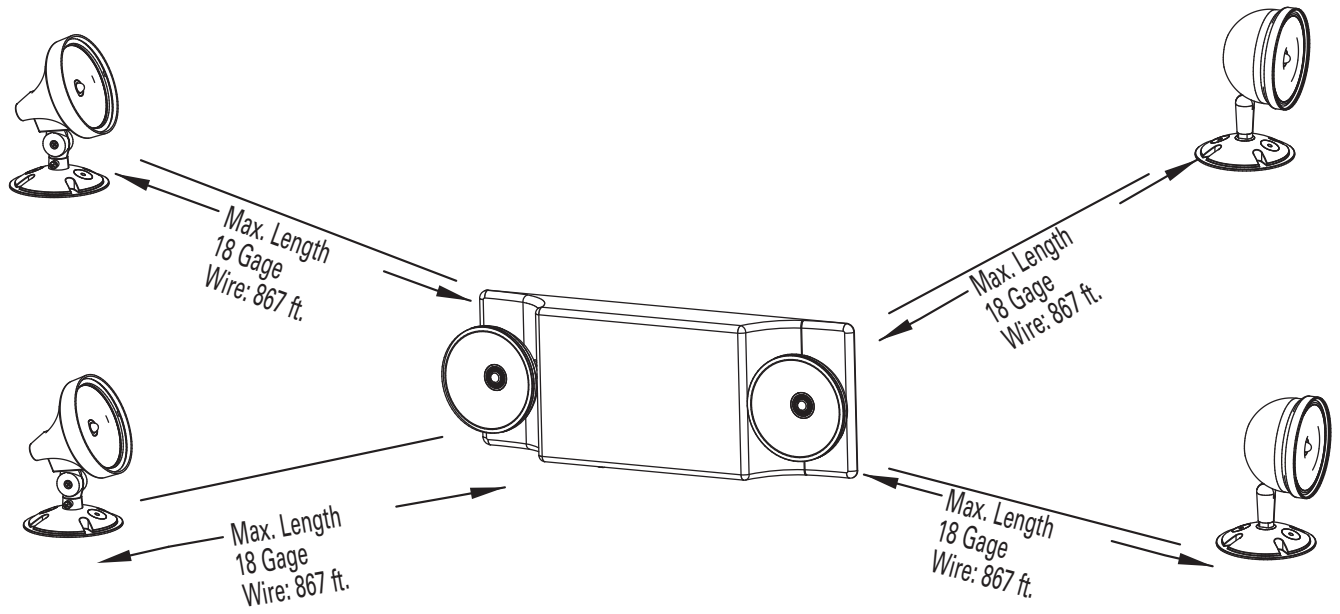

Another option would be to put all four heads on individual 12 gage circuits. Since each circuit would only have only one head, the maximum length of each circuit could be 867 feet.

NOTE: DO NOT exceed maximum output wattage of the base unit.

TROUBLE SHOOTING GUIDE

If LED remotes do not light, or strobe, check the following:

1. Voltage at the battery with the AC power disconnected. Make sure the voltage meets or exceeds the rated battery voltage.
2. Voltage at the remote light end of the wire. The SRP and SRM LED remotes are designed to operate between 4.8 and 12VDC. If the voltage at the junction box is below this voltage, or shows a significant difference from the battery voltage, it may be necessary to increase the size of the wire between the remote and the source unit equipment.
3. If following the above trouble shooting hints does not solve your problem, contact your local Cooper Lighting Solutions representative for assistance.

WARRANTIES AND LIMITATION OF LIABILITY

Please refer to www.cooperlighting.com for our terms and conditions.



Cooper Lighting Solutions
1121 Highway 74 South
Peachtree City, GA 30269
P: 770-486-4800
www.cooperlighting.com

© 2020 Cooper Lighting Solutions
All Rights Reserved
Printed in USA
Imprimé aux États-Unis
Impreso en los EE. UU.
Publication No. IB505011EN
December 10, 2015 11:31 AM

Cooper Lighting Solutions is a
registered trademark.
All trademarks are property
of their respective owners.

Cooper Lighting Solutions est une
marque de commerce déposée. Toutes
les autres marques de commerce sont
la propriété de leur propriétaire
respectif.

Cooper Lighting Solutions es una
marca comercial registrada. Todas las
marcas comerciales son propiedad de
sus respectivos propietarios.

Product availability, specifications,
and compliances are subject to
change without notice

La disponibilité du produit, les
spécifications et les conformités
peuvent être modifiées sans préavis

La disponibilidad de productos, las
especificaciones y los cumplimientos
están sujetos a cambio sin previo aviso