

PHILIPS

CoreLine Trunking Gen2

LL217X BV, LL234X BV

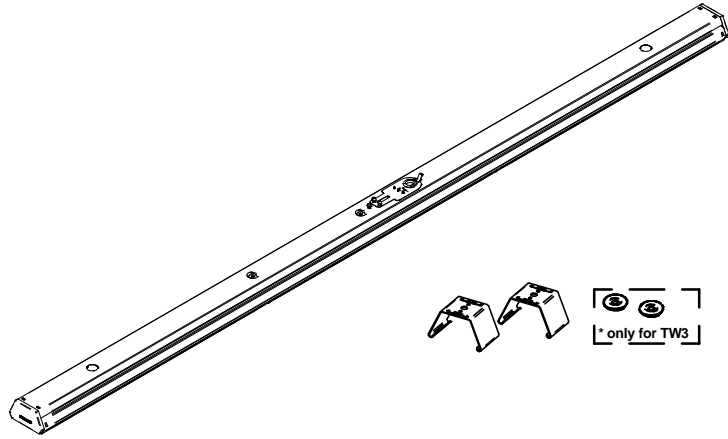

* only for TW3

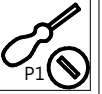

GLOW WIRE
850°C



Prevent water from entering on or in the luminaire at installation and during use of the luminaire.

Description LED module	Final light source class
FO LED STRIP OC 2FT 2250LM 830 BC HV5	C
FO LED STRIP OC 2FT 2250LM 840 BC HV5	C
FO LED STRIP OC 2FT 2250LM 865 BC HV5	C
FO LED STRIP OC 2FT 2200LM 830 BC HV5	D
FO LED STRIP OC 2FT 2200LM 840 BC HV5	D
FO LED STRIP OC 2FT 2200LM 865 BC HV5	D

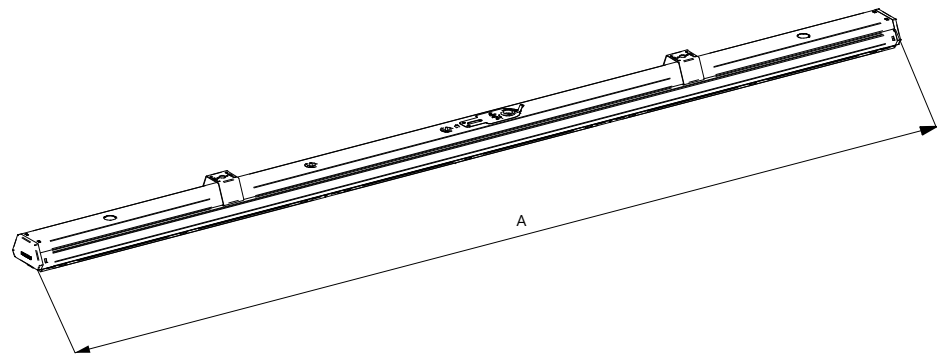
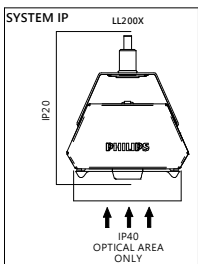
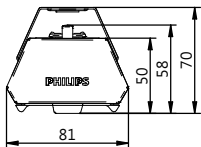
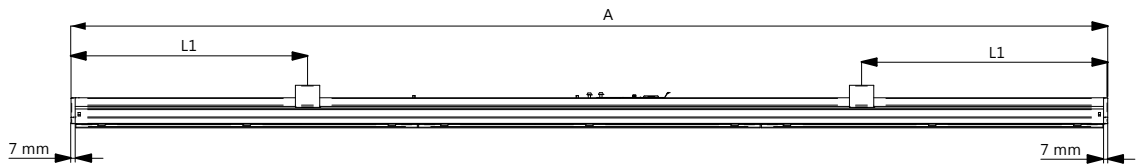

Luminaire type		SYSTEM FLUX [Lm]	Wattage [W]	A [mm]	L1 [mm]	kg
LL217X	45S PSU BV	4500	27	1714	500 - 800	3,0
	80S PSU BV	8000	50			
	80S PSU HE BV	8000	48			
	120S PSU BV	12000	80			
LL234X	90S PSU BV	9000	54	3414	500 - 800	5,8
	160 PSU BV	16000	100			
	160 PSU HE BV	16000	96			
	240S PSU BV	24000	160			

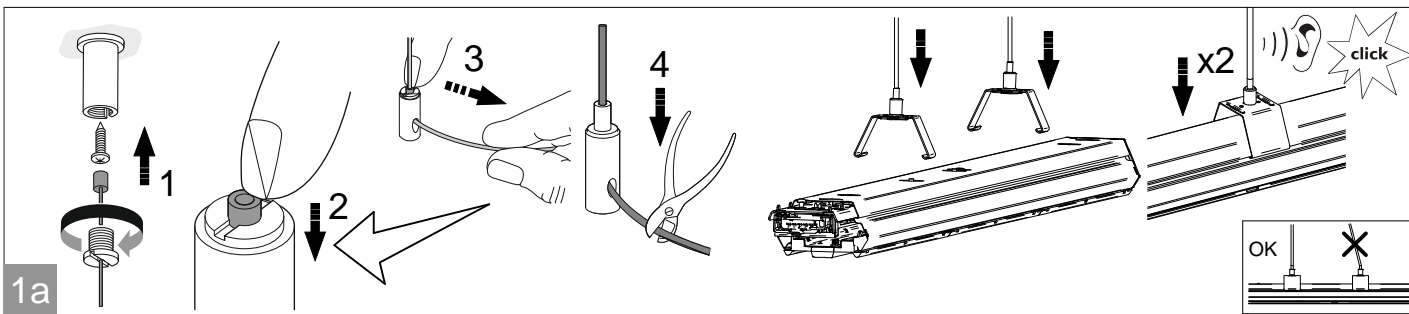

Drawing	Accessories
1a	LL200Z MB-SW
1b	LL200Z CB
1c	LL200Z SMB
1d	LL200Z PB
1e	LL200Z SMB-TPM SET

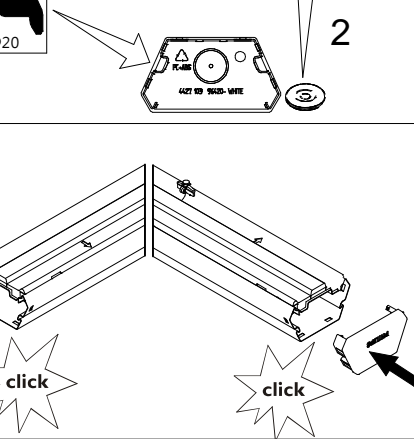
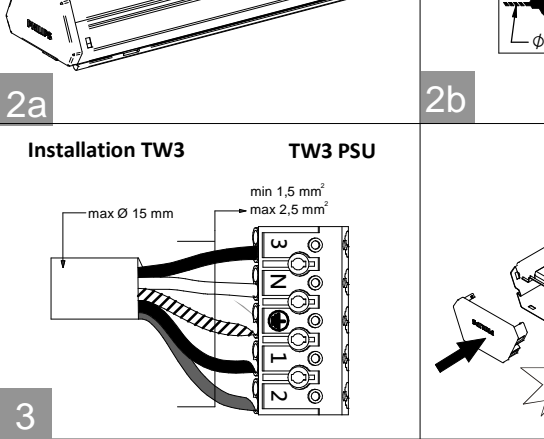
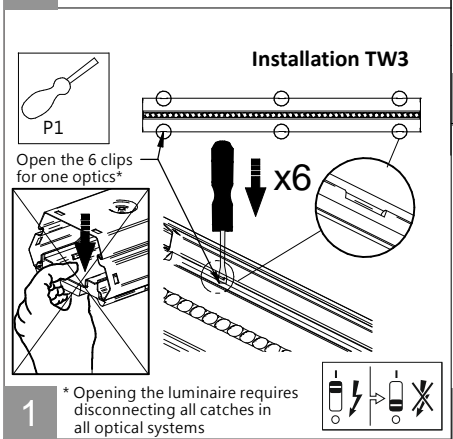
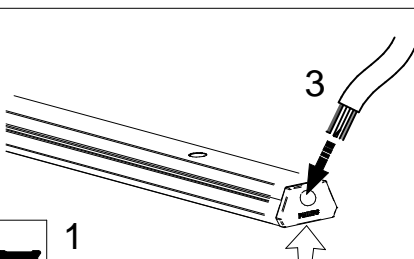
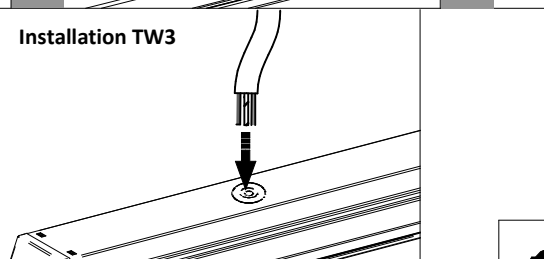
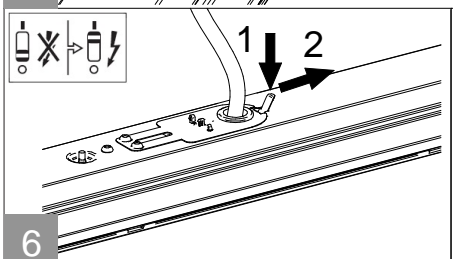
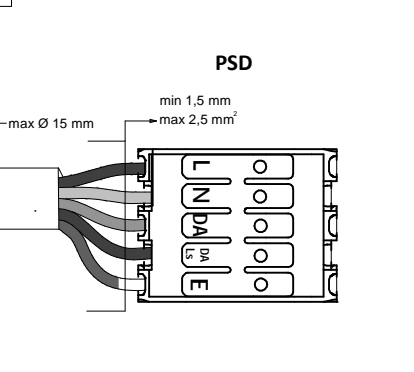
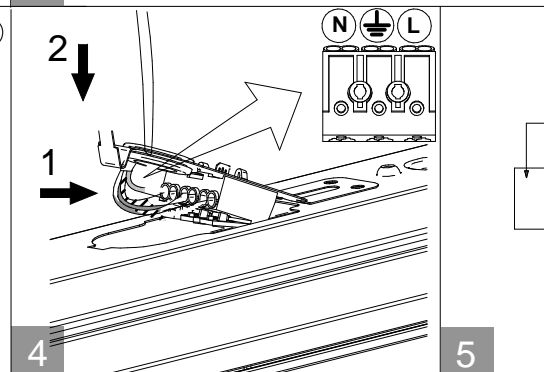
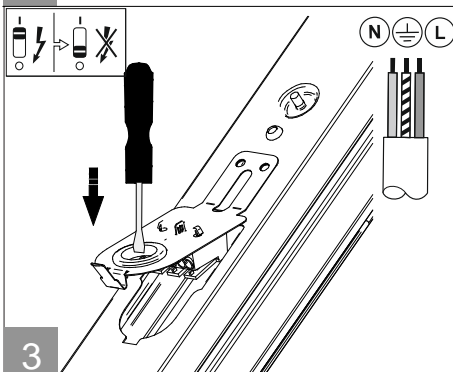
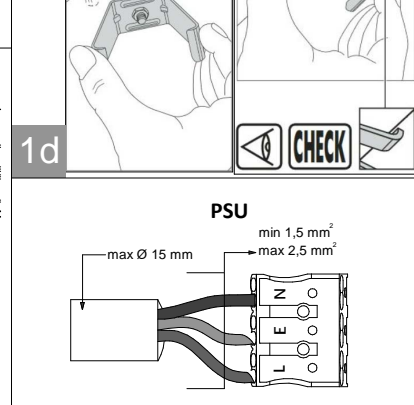
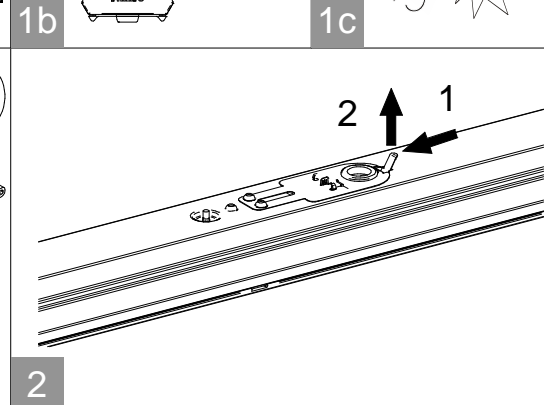
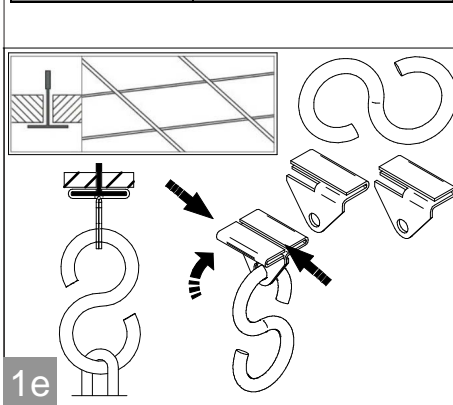
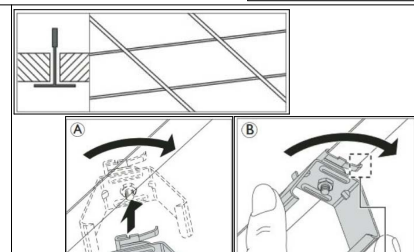
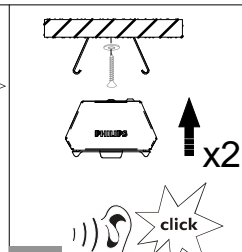
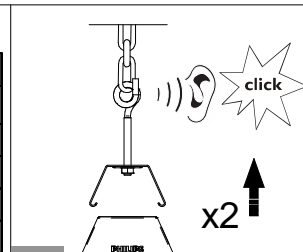

1 * Opening the luminaire requires disconnecting all catches in all optical systems

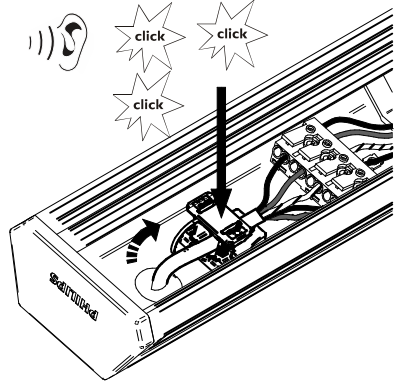

4

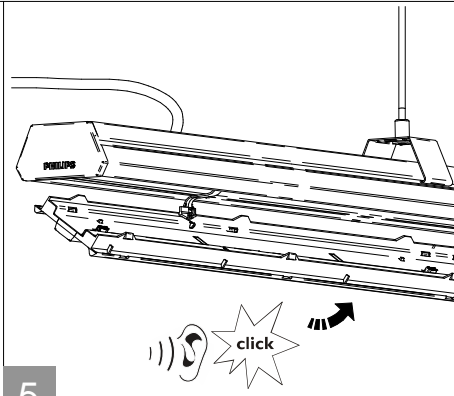

5

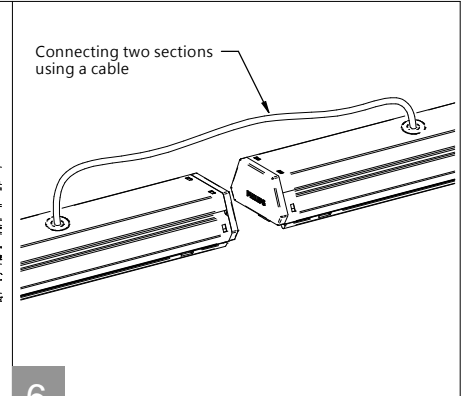

6

Inrush current

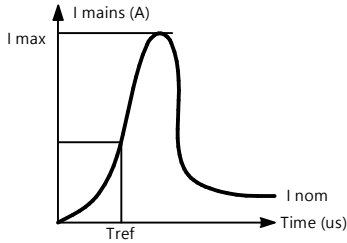

TYPE	55S 1xPSU (36W)	30S/45S 1xSRD (35W)	90S 2x SRD (35W)	30S/45S 1xPSD (35W)	90S 2xPSD (35W)	30S/45S/53S/80S 1xPSD (60W)	90S/160S 2xPSD (60W)	53S/80S 1xSRD (60W)	160S 2xSRD (60W)	45S/80S 1xPSU (75W)	90S/160S 2xPSU (75W)	80S/120S 1xPSU (100W)	240S 2xPSU (100W)	80S/90S/120S 1xPSD (100W)	240S 2xPSD (100W)	80S/90S/120S 1xSRD (100W)	240S 2xSRD (100W)	80S/120S/160S 1xPSD (150W)	240S 2xPSD (150W)	160S 1xSRD (150W)
I max [A]	14,0	21,0	42,0	23,1	46,2	25,1	50,2	21,0	42,0	19,0	38,0	22,5	45,0	10,0	20,0	4,5	9,0	5,1	10,2	5,1
Tref [µs]	250	280	280	221	221	214	214	280	280	280	280	30	30	35,9	35,9	1000	1000	760	760	760
cable Ø [mm²]	1.5 / 2.5*																			
MCB B-6A	13/13	8/8	4/4	8/8	4/4	8/8	4/4	8/8	4/4	9/9	4/4	9/9	4/4	7/7	3/3	7/7	3/3	6/6	3/3	4/4
MCB B-10A	20/20	13/13	6/6	13/13	6/6	13/13	6/6	13/13	6/6	15/15	7/7	14/14	7/7	11/11	5/5	11/11	5/5	10/10	5/5	7/7
MCB C-10A	34/34	21/21	10/10	22/22	11/11	21/21	10/10	21/21	10/10	24/24	12/12	23/23	11/11	18/18	9/9	18/18	9/9	16/16	8/8	12/12
MCB B-13A	26/26	17/17	8/8	17/17	8/8	17/17	8/8	17/17	8/8	19/19	9/9	18/18	9/9	14/14	7/7	14/14	7/7	12/12	6/6	9/9
MCB C-13A	40/44	28/28	14/14	29/29	14/14	28/28	14/14	28/28	14/14	32/32	16/16	30/31	15/15	24/24	12/12	24/24	12/12	20/21	10/10	16/16
MCB B-16A	33/33	21/21	10/10	22/22	11/11	21/21	10/10	21/21	10/10	24/24	12/12	23/23	11/11	18/18	9/9	18/18	9/9	16/16	8/8	12/12
MCB C-16A	40/56	35/35	17/17	37/37	18/18	35/35	17/17	35/35	17/17	40/40	20/20	30/39	15/19	30/30	15/15	30/30	15/15	20/27	10/13	20/20

* Warning! The values on the left are for 1.5 mm thick cables, the values on the right are for 2.5 mm thick cables

Maintenance instructions

To assure the lighting quality of this unique LED lighting concept there are a few instructions regarding the maintenance of this LED luminaire:

- Do not touch electronic components!
Electronic components are under high voltage.
Electronic components are ESD sensitive.
- During installation or when maintaining the luminaire please use static free gloves to avoid marks on the luminaire.
- To remove dirt and spots use the following:
Dust: only use micro fiber cloths
Fingerprints, etc.: use a cleaner for synthetic materials with antistatic properties.
- Do not stare into the LED light beam.
- To avoid scratches and dirt on optical parts remove protective foil after installation.
- The luminaire shall be installed by a qualified electrician and wired in accordance with the latest IEE electrical regulations or the national requirements.
- The light source of this luminaire is not replaceable: when the light source reaches its end of life whole luminaire shall be replaced.
- Driver insulation: Basic according to IEC 61847-1.

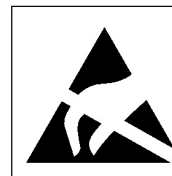
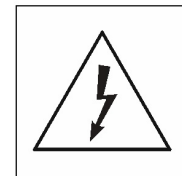
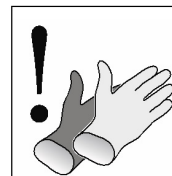

ATTENTION
OBSERVE PRECAUTIONS
FOR HANDLING
ELECTROSTATIC
SENSITIVE
DEVICES



GB - Disconnect before servicing
 FR - Mettre hors tension avant intervention
 DE - Offnenurspannungsfrei
 NL - Stroomafsluiten voor onderhoud
 LT - Pirms apkopas atvienojiet nuo elektros tinkleidžių
 EE - Katkesta elektriitoidene valvustust
 PT - Desconecte antes de fazer a manutenção

DK - Frakobl, før service
 NO - Koble fra før service
 FI - Irrota pistoke ennen huoltoon
 CZ - Před servisem se odpojte
 TR - Servis yapmadan önce baglantıyı kesin
 HR - Prije servisiranja isključite
 GR - Αποσυνδέστε πριν από τη συντήρηση
 BG - Изключете преди сервис
 RU - Отключите перед обслуживанием
 LV - Pirms apkopas atvienojiet to

IT - Toglieretensione prima di fare manutenzione
 ES - Desconectar antes de manipular
 SE - Bryt strömmen före lampbytte
 SK - Odpojit pred údržbou
 SI - Pred servisiranjem izključite svetilko
 HU - Karbantartás előtt húzza ki a csatlakozót
 PL - Odłącz przed serwisowaniem
 RO - Deconectați-vă înainte de întreținere

GB Luminaire has basic insulation between Low Voltage supply and control conductors.
 ES La luminaria tiene un aislamiento básico entre la alimentación de baja tensión y los cables de la señal de control.
 PT A luminária tem um isolamento básico entre a alimentação de baixa tensão e os cabos de sinal de controlo.
 DE Die Leuchte verfügt über eine einfache Isolation zwischen der Niederspannungsversorgung und den Steuerleitungen.
 FR Le luminaire comporte une isolation de base entre l'alimentation basse tension et les câbles de contrôle.
 IT Il grado di isolamento tra il conduttore di alimentazione ed il conduttore di segnale è básico.
 NL Armatuur heeft een basisisolatie tussen laagspannings-voeding en controle bedrading.
 DK Armaturet har enkelisolering mellem lavvoltageforsyningen og styreledningerne.

SE Armaturen har enkelisolering mellan lågvoltförsörjningen och styreledningarna.
 NO Armaturet har enkelisolering mellom lavvoltageforsyningen og styreledningene.
 FI Valaisimessa on peruseristys syöttöjännitteen ja ohjausohjotmien välillä.
 HU A lámpatestet kifesztésű és szabályozó bemenetei galvanikusan elvannak választva.
 RO Corpul de iluminat dispune de izolație de bază între sistemul de alimentare de joasă și conductorii de control.
 BG Осветителното тяло има основна изолация между захранването ниско напрежение и контролните проводници.
 RU Светильник обладает базовой электроизоляцией между низковольтным блоком питания и управляющими проводниками.
 PL Oprawa posiada podstawową izolację pomiędzy modulem zasilania niskonapięciowego i przewodami sterującymi.

GR Το φωτιστικό διαθέτει βασική μόνωση μεταξύ της χαμηλής τάσης τροφοδοσίας και των αγωγών ελέγχου.
 CZ Ve svítidle je mezi vodiči napájení a řízení základní izolace.
 TR Armatür, Alçak Gerilim beslemesi ile kontrol ilekleri arasında temel izolasyona sahiptir
 SK Svetidlo má základnú izoláciu medzi vodičmi zdroja nízkeho napätia a riadiacimi vodičmi.
 LT Šviestuvos turi elementarią izoliaciją tarp žemos įtampos maitinimo ir valdymo laidų.
 LV Gaismeklīm ir pamata izolācija starp zemsprieguma barošanas un vadības aprīkojuma.
 EE Valgustil on põhisolatsioon madalpinge toite ja juhtimiseadmete vahel.
 SI Svetilka ima osnovno izolacijo med nizkonapetostnimi napajalnimi in regulacijskimi vodniki.
 HR Svjetiljka ima osnovnu izolaciju između napajanja i upravljačkih konektora.

GB The light source and/or control gear and/or the external flexible cable contained in this luminaire shall only be replaced by the manufacturer or his service agent or a similar qualified person.
 ES La fuente de luz/o el driver / o el cable flexible contenido en la luminaria solo podrá ser sustituido por el fabricante o su agente de servicio o por una persona cualificada.
 PT A fonte de luz e/ou o equipamento de controlo e/ou o cabo externo flexível nesta luminária só devem ser substituídos pelo fabricante ou pelo seu agente de serviço ou por pessoa qualificada para tal.
 DE Die in dieser Leuchte enthaltene Lichtquelle und/oder das Betriebsgerät und/oder das externe flexible Anschlusskabel darf nur vom Hersteller oder seinem Kundendienst oder einer ähnlich qualifizierten Person ausgetauscht werden.
 FR La source lumineuse et/ou le contrôleur de courant et/ou le câble souple d'alimentation contenus dans ce luminaire ne doivent être remplacés que par le fabricant, un de ses agents ou une personne qualifiée.
 IT La sorgente luminosa e/o il dispositivo di controllo e/o il cavo flessibile esterno contenuti in questo apparecchio di illuminazione sono sostituiti solo dal costruttore o dal suo agente di servizio o da una persona qualificata analoga.
 NL De lichtbron en/of voorschakelapparatuur en/of de flexibele voedingskabel van dit armatuur mag alleen vervangen worden door de fabrikant of haar service dealer of een vergelijkbaar gekwalificeerd persoon.
 DK Lyskilden og/eller driver og/eller eksterne kabler indeholdt i dette armatur må kun udskiftes af producenten eller godkendt service partner eller lignende kvalificeret person.
 SE Ljuskällan och/eller styrsystemet och/eller den externa kabeln i denna armatur får endast bytas ut av tillverkaren eller en kvalificerad person.
 NO Lyskilden og/eller driveren og/eller den eksterne kabelen i dette armaturet skal bare erstattes av produsenten eller dens service agent eller tilsvarende kvalifisert person.
 CZ Světelný zdroj a/nebo napájecí zdroj (předřadník) a/nebo flexibilní napájecí kabel v tomto svítidle smí vyměňovat pouze výrobce nebo jeho servisní technik nebo obdobně kvalifikovaná osoba.
 HU A lámpatestben található fényforrást és/vagy működtető szerelvény és/vagy a külső rugalmas kábelt csak a gyártó, a gyártóval szerződött cég vagy megfelelő képzéssel rendelkező szakember cserélheti ki.
 PL Źródło światła i/lub zasilacz i/lub zewnętrzny przewód zasilający, który jest wprawdzie powinien być wymieniony przez producenta lub jego serwisanta lub kwalifikowany personel.

RO Sursa de lumină și / sau aparatul și / sau cablul flexibil extern conținut în acest aparat de iluminat trebuie înlocuite numai de producător sau de agentul său de service sau de o persoană calificată similară.
 FI Tässä valaisimessa oleva valonlähde ja/tai muut komponentit, kuten liitäntälaitte ja/tai ulkoiset kaapelit saadaan vaihtaa vain valmistajan tai tämän valtuuttaman huoltoedustajan tai vastaavan pätevän henkilön toimesta.
 TR Bu armatürde bulunan ışık kaynağı ve / veya kontrol tertibatı ve/ veya hariç esnek kablo, yalnızca imalatçı veya onun servis temsilcisi veya benzer bir kalifiye kişi tarafından değiştirilmelidir.
 HR Izvor svjetlosti i / ili predspojna naprava i / ili vanjski fleksibilni napojni kabel sadržan u ovoj svjetiljci smije zamijeniti samo proizvođač, ovlašten servis ili adekvatna stručno osposobljena i ovlaštena osoba.
 GR Η φωτεινή πηγή ή/και τα όργανα έναυσης/ελέγχου ή/και το εξωτερικό εύκαμπτο καλώδιο που περιέχεται στο εν λόγω φωτιστικό πρέπει να αντικαθίστανται μόνο από τον κατασκευαστή ή τον αντιπρόσωπο εέρβις ή παρόμοιο ειδικευμένο πρόσωπο.
 BG Източникът на светлина и / или пусково-регулируща апаратура и / или външният гъвкав кабел, съдържащ се в това осветително тяло, трябва да бъдат заменени само от производителя или неговия оторизиран сервис или подобно квалифицирано лице.
 RU Источник света и / или ПРА и / или внешний гибкий кабель, содержащийся в этом светильнике, могут быть заменены только производителем, его агентом по обслуживанию или аналогичным квалифицированным лицом.
 SK Svetelný zdroj a/alebo predradník a/alebo externý flexibilný kábel obsiahnutý v tomto svítidle môže byť vymenený len výrobcom alebo servisným partnerom alebo inou podobne kvalifikovanou osobou.
 LT Šviesos šaltinis ir/arba valdymo įrenginys ir/arba išorinis lankstus kabelis esantis šiame šviestuve gali būti pakeistas tik gamintojo arba jo aptarnavimo agento ar tai atitinkančio kvalifikuoto asmens.
 LV Gaismas avota un / vai vadības ierīci un / vai ārējo elastīgo kabeli, kas atrodas šajā gaismeklī, drīkst nomainīt tikai ražotājs vai viņa servisa pārstāvis vai līdzīga kvalificēta persona.
 EE Selles valgustis sisalduva valgusallika ja/või juhtimiseadme ja/või väliste painduva kaabli võib välja vahetada ainult tootja, vastav hooldusspetsialist või muu sarnane kvalifitseeritud isik.
 SI Vir svetlobe in / ali napajalnik in / ali zunanji prilagodljivi kabel, ki ga vsebuje ta svetilka, lahko zamenja le proizvajalec ali njegov servis ali podobna usposobljena oseba.