

## Installation Instructions for the AUX Universal Edge Lit Exit – AC Only

### WARNING

#### Risk of Fire/Electric Shock

If not qualified, consult an electrician.

### WARNING

#### Risk of Electric Shock

Disconnect power at fuse or circuit breaker before installing or servicing.

### Important Safeguards

WHEN USING ELECTRICAL EQUIPMENT, BASIC SAFETY PRECAUTIONS SHOULD ALWAYS BE OBSERVED INCLUDING THE FOLLOWING.

1. READ AND FOLLOW ALL SAFETY INSTRUCTIONS
2. Dry location only. Do not use outdoors.
3. Do not use in hazardous locations, or near gas or electric heaters.
4. Do not let power supply cords touch hot surfaces.
5. Do not use this equipment for other than the intended use.
6. Installation is to be performed only by qualified personnel.
7. Install in accordance with National Electric Code and local regulatory agency requirements.
8. The use of accessory equipment not recommended by the manufacturer may cause an unsafe condition.
9. Equipment should be mounted in locations and at heights where it will not readily be subjected to tampering by unauthorized personnel.
10. SAVE THESE INSTRUCTIONS

### For Recessed Installation

1. Turn off power supply.
2. Determine if the fixture will be mounted in the ceiling or the wall.
3. Remove the screws securing the trim plate to the housing (See Figure 1). Place the trim assembly and screws aside and save them for later installation. It is not necessary to disconnect the wire harness connecting the charger driver circuit board to the LED board. Instead, the trim plate can be hung from the sliding plastic installation hook (see figure 2).

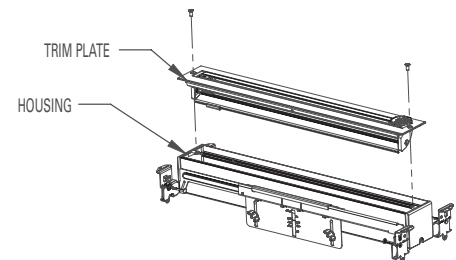

FIGURE 1

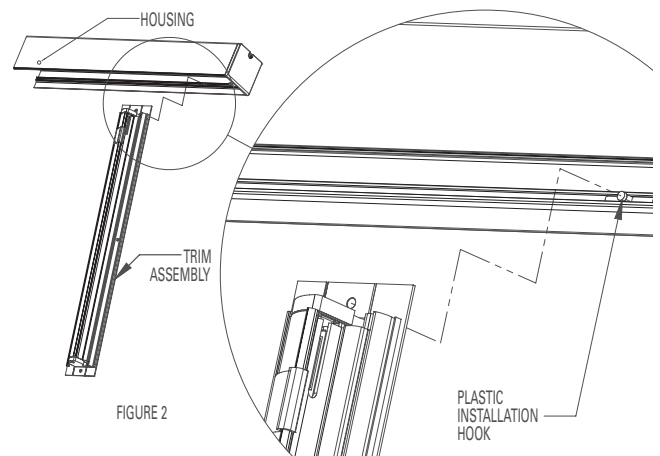

FIGURE 2

4. Determine where supply wires will be brought into the fixture. There are knockouts in each endcap on the side of the housing, and a hole between the hanger bars. If the hole between the hanger bars is to be used, remove the two screws holding the cover plate and the hanger bars, discard the plate, and then replace the screws and hanger bars.
5. Install the housing using the hanger bars. The hanger bars can be extended up to 25.5"; and are designed to be nailed or screwed to studs, clipped onto the T-grid of a suspended ceiling, or be suspended from wires. If the hanger bars need to be configured perpendicular to the fixture, the hanger bar brackets can be attached at the ends of the fixture using the screws provided (See Figure 3).
6. Adjust the fixture to accommodate the thickness of drywall, plaster, or ceiling tile to be used. The notches and markings on the hanger bar holders correspond to the material thickness (See Figure 4).

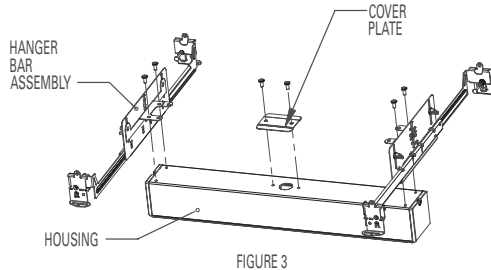

FIGURE 3

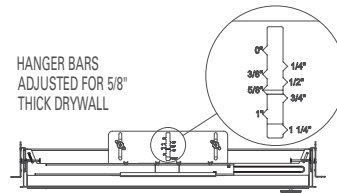

FIGURE 4

7. Connect power supply and ground in accordance with NEC and local codes. Wire connections are as follows: Ground to Green Lead, Neutral to White Lead, 277V line to Orange Lead (if used), 120V line to Black Lead (if used). Cap unused Line Lead. (See Schematic)
8. If the fixture is to be wall mounted, first, loosen the set screw on the back of the pivot housing. Then remove the locking clip by sliding it to the end of the pivot housing (See Figure 5). Rotate the pivot housing 90 degrees, and then replace the locking clip. Tighten the set screw.
9. Remove the trim assembly from the installation hook. Slide the trim assembly through the trim cover so that it can be installed between the trim assembly and the ceiling or wall.
10. Replace the screws holding the trim assembly to the housing.
11. Lens is provided in a separate box. Apply chevrons and background as needed. Snap lens into place.

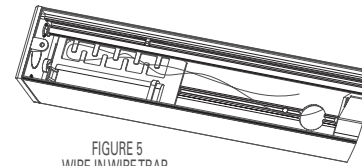

FIGURE 5  
WIRE IN WIRE TRAP

NOTE: If using the lens with the default transparent background (instead of the provided white or mirror backgrounds) it must be installed only where there is adequate color contrast between the sign legend and the interior wall finish behind the sign, to provide for sufficient visibility.

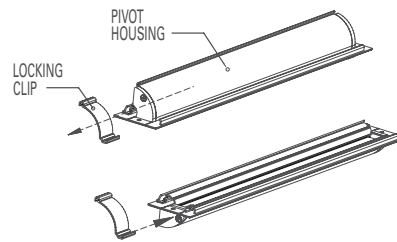

FIGURE 6

12. Turn on power to fixture

### For Surface Installation:

1. Turn off power supply.
2. Remove the two screws securing the hanger bar brackets and hanger bars. Remove the hanger bar assemblies.
3. Determine if the fixture will be mounted on the ceiling, wall, or end mounted.

- For wall or ceiling mount, attach the canopy over the hole in the center of the housing using the screws used to hold the hanger bar brackets (See Figure 7).

- For end mount, remove the endcap on the desired end, and replace it with the canopy and guide bracket (See Figure 8). Replace the cover plate over the hole in the center of the housing.

4. Remove the screws securing the trim plate to the housing (See Figure 1). Place the trim assembly and screws aside and save them for later installation. It is not necessary to disconnect the wire harness connecting the charger driver circuit board to the LED board. Instead, the trim plate can be hung from the sliding plastic installation hook (See Figure 2).

Secure the canopy to the junction box using the adapter plate and screws provided (See Figure 7/8). The adapter plate is designed to be connected to a NEMA standard 3.5" round, 4" round, 3.5" octagon, 4" octagon, or handy (single gang) box. However, it is possible to connect the adapter plate to other electrical boxes with some modification.

5. Connect power supply and ground in accordance with NEC and local codes. Wire connections are as follows: Ground to Green Lead, Neutral to White Lead, 277V line to Orange Lead (if used), 120V line to Black Lead (if used). Cap unused Line Lead. (See Schematic)

6. If the fixture is to be wall mounted, first, loosen the set screw on the back of the pivot housing. Then remove the locking clip by sliding it to the end of the pivot housing (See Figure 6). Rotate the pivot housing 90 degrees, and then replace the locking clip. Tighten the set screw.

7. Remove the trim assembly from the installation hook.

8. Replace the screws holding the trim assembly to the housing.

9. Lens is provided in a separate box. Apply chevrons and background as needed. Snap lens into place.

NOTE: If using the lens with the default transparent background (instead of the provided white or mirror backgrounds) it must be installed only where there is adequate color contrast between the sign legend and the interior wall finish behind the sign, to provide for sufficient visibility.

10. Turn on power to fixture.

**MAINTENANCE:** None required.

**NOTE:** Servicing of any parts should be performed by qualified personnel. Only use replacement parts supplied by Cooper Lighting Solutions. Use of unauthorized parts may void the warranty

**TROUBLE SHOOTING HINTS:**

If LED display or charge indicator LED does not illuminate, check the following:

1. Check AC supply – verify that unit has 24 hour AC supply.
2. Unit is shorted.
3. If following the above trouble shooting hints does not solve your problem, contact your local Cooper Lighting Solutions representative for assistance.

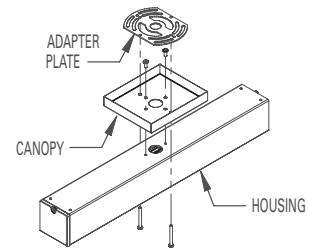

FIGURE 7

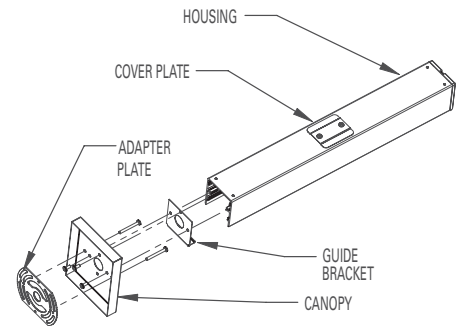
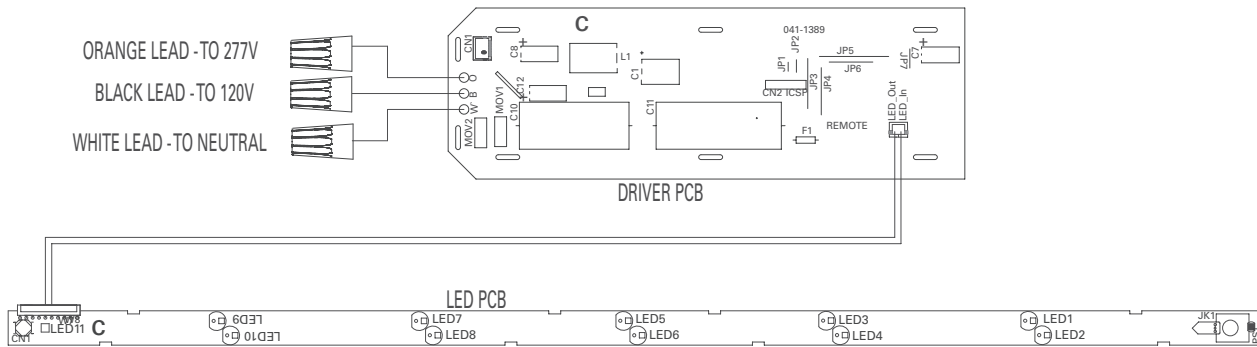

FIGURE 8

## SCHEMATIC:



Voltages and wire colors may vary for international versions. Check wire tags.

## DISCLAIMER OF WARRANTIES AND LIMITATION OF LIABILITY

The information, recommendations, descriptions and safety notations in this document are based on Cooper Lighting Solutions' experience and judgment and may not cover all contingencies. If further information is required, a Cooper Lighting Solutions sales office should be consulted. Sale of the product shown in this literature is subject to the terms and conditions outlined in appropriate Cooper Lighting Solutions selling policies or other contractual agreement between Cooper Lighting Solutions and the purchaser.

THERE ARE NO UNDERSTANDINGS, AGREEMENTS, WARRANTIES, EXPRESSED OR IMPLIED, INCLUDING WARRANTIES OF FITNESS FOR A PARTICULAR PURPOSE OR MERCHANTABILITY, OTHER THAN THOSE SPECIFICALLY SET OUT IN ANY EXISTING CONTRACT BETWEEN THE PARTIES. ANY SUCH CONTRACT STATES THE ENTIRE OBLIGATION OF COOPER LIGHTING SOLUTIONS. THE CONTENTS OF THIS DOCUMENT SHALL NOT BECOME PART OF OR MODIFY ANY CONTRACT BETWEEN THE PARTIES.

In no event will Cooper Lighting Solutions be responsible to the purchaser or user in contract, in tort (including negligence), strict liability or otherwise for any special, indirect, incidental or consequential damage or loss whatsoever, including but not limited to damage or loss of use of equipment, plant or power system, cost of capital, loss of power, additional expenses in the use of existing power facilities, or claims against the purchaser or user by its customers resulting from the use of the information, recommendations and descriptions contained herein. The information contained in this manual is subject to change without notice.

**Cooper Lighting Solutions**  
1121 Highway 74 South  
Peachtree City, GA 30276  
P: 770-486-4800  
www.cooperlighting.com

© 2020 Cooper Lighting Solutions  
All Rights Reserved  
Printed in USA  
Publication No. ADA140171

Cooper Lighting Solutions is a registered trademark.

All trademarks are property of their respective owners.