



Greengate

SuperSwitch® Ultrasonic Wall Switch 120/277 VAC

Installation Instructions

P/N 9850-000408-00



Model # OSW-U-0721-MV-A
Model # OSW-U-0721-MV-V
Model # OSW-U-0721-MV-W

General Information

- Read all instructions on both sides of this sheet first
- Plan all component locations carefully
- Install in accordance with all local codes
- One model for either 120 VAC or 277 VAC
- Not for use where temperatures fall below 32° F or exceed 100° F
- For indoor use only
- No leakage to load in OFF mode

Specifications

Technology: Ultrasonic
Electrical Ratings:
 120 VAC:
 • Incandescent/Tungsten – Max. load: 6.7 amps, 800W, 60 Hz
 • Fluorescent/Ballast – Max. load: 6.7 amps, 800W, 60 Hz
 Motor Load: ¼ HP @ 125 VAC
 277 VAC:
 • Fluorescent/Magnetic Ballast – Max. load: 4.3 amps, 1200W, 60 Hz
Ballast Compatibility: Compatible with magnetic ballasts
No Minimum Load Requirement
Time Delays: 15 seconds to 15 minutes

Coverage: Major motion – 500 sq. ft.
 Minor motion – 300 sq. ft.

Operating Environment:
 • Temperature: 60° F – 80° F (15° C – 26° C)
 • Relative Humidity: Less than 95% non-condensing
 For indoor use only

Housing: Durable, injection molded housing. ABS resin complies with UL 94V-0.

Size:
 • Mounting Plate Dimensions: 4.15" H x 1.94" W (105.41 mm x 49.28 mm)
 • Product Housing Dimensions: 2.73" H x 1.8" W x 1.8" D (69.34 mm x 45.72 mm x 45.72 mm)

LED Indicators: Red LED for Ultrasonic detection

Description

OSW-U-0721-MV is a self-contained motion-sensing lighting control device that replaces a conventional wall switch for energy savings and convenience. Built-in sensors produce low intensity, inaudible sound and detect changes in sound waves caused by motion, such as walking into the room, reaching for a telephone, turning in a chair. The sensor does not respond to audible sound. Lights turn OFF automatically after a room is vacated.

The device offers a choice of Automatic ON or Manual ON modes. In the Automatic ON mode, the lights turn ON automatically when a person enters the room. In the Manual ON mode, lights are turned ON by pressing the touchplate ON the switch. Modes can be changed by flipping the concealed switch under the touchplate. (See Checkout and Adjustment). In either mode, lights will remain ON as long as motion is detected in the room. When no motion is detected, the lights will turn OFF automatically after the pre-set time delay. Following this, a "grace period" of approximately ten seconds allows lights to be turned ON again by motion.

At any time, lights may be turned OFF while the room is occupied by pressing the touchplate. OSW-U-0721-MV is fully self-resetting; lights turned OFF manually in Automatic ON mode will stay OFF while the room remains occupied. After the room is vacated and the pre-set time delay and grace period have elapsed, the lights will remain OFF until turned ON automatically the next time someone enters the room.

OSW-U-0721-MV can be used with a standard toggle switch to split the lighting load for rooms that are wired for two switches as shown in the Wiring Diagram.

Coverage

The OSW-U-0721-MV is designed for offices up to 300 square feet. Wall switches are normally mounted off-center in a room which reduces the coverage attainable.

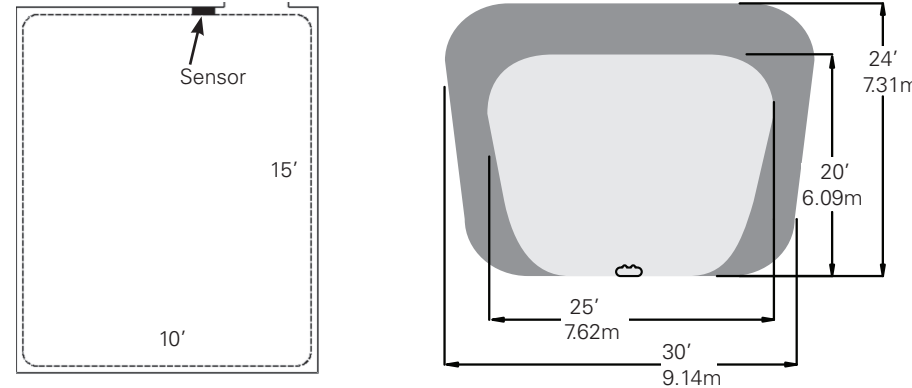

Location

When installing the OSW-U-0721-MV in a new junction box, choose the switch location carefully to provide optimum coverage of the occupied area. When replacing an existing wall switch, bear in mind that there must be a clear line of sight between the OSW-U-0721-MV and the area to be covered. Avoid pointing the OSW-U-0721-MV directly into the hallway where it may detect passers-by.

Installation

The OSW-U-0721-MV can replace one switch in any standard single or double gang box. It may be installed in the same manner as an ordinary wall switch.

For safety purposes before installing or doing any service on the OSW-U-0721-MV, the power must be turned OFF at the circuit breaker panel. Wire the OSW-U-0721-MV as described in the wiring section. Mount the OSW-U-0721-MV in the junction box.

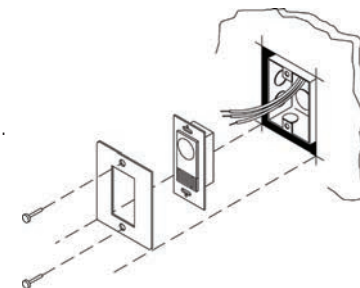

Wiring

CAUTION: Before installing or performing any service on a Greengate system, the power MUST be turned OFF at the branch circuit breaker. According to NEC 240-83(d), if the branch circuit breaker is used as the main switch for a fluorescent lighting circuit, the circuit breaker should be marked "SWD." All installations should be in compliance with the National Electric Code and all state and local codes.

NOTE REGARDING COMPACT FLUORESCENT LAMPS: The life of some compact fluorescent lamps (CFLs) is shortened by frequent automatic or manual switching. Check with CFL and ballast manufacturer to determine the effects of cycling.

CAUTION: Model OSW-U-0721-MV is for use with either 120 VAC or 277 VAC only. For other voltages refer to product spec sheet. Do not wire to control receptacle circuits.

VERIFY that the connected load does not exceed the OSW-U-0721-MV ratings. There is no minimum load requirement. Use twist-on wire connectors for all connections. Model OSW-U-0721-MV can be wired to control both an exhaust fan and lighting provided the total load does not exceed the maximum load rating (in Amps) for the automatic wall switch.

1. Connect the white lead to the neutral.
2. Connect the red lead to the switch leg for Load 1 and to one terminal of the toggle switch.
3. Connect the other toggle switch terminal to the switch leg for Load 2.
4. Connect the black wire to the hot lead.

Note: Connections are polarity sensitive.

CAUTION: If a room is wired for two circuits using two separate hot leads, it is very important to connect only one circuit to the OSW-U-0721-MV. Split one circuit into two switch legs and cap the unused hot lead inside the box. The OSW-U-0721-MV must always control Load 1, while its control of Load 2 is selected manually by opening and closing the toggle switch.

Wiring Diagram 1: Single Level Switching

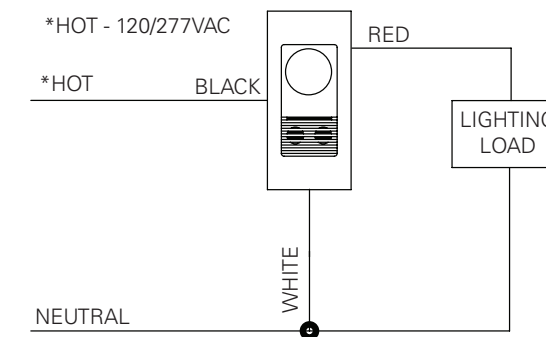

Wiring Diagram 2: Dual Level Switching using additional toggle switch

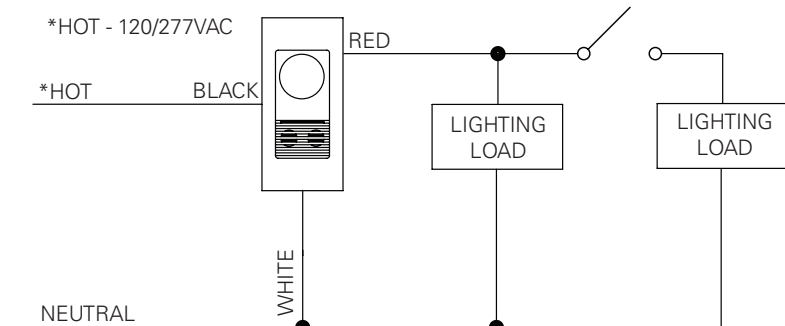

Wiring Diagram 3: For Three-Way Wiring

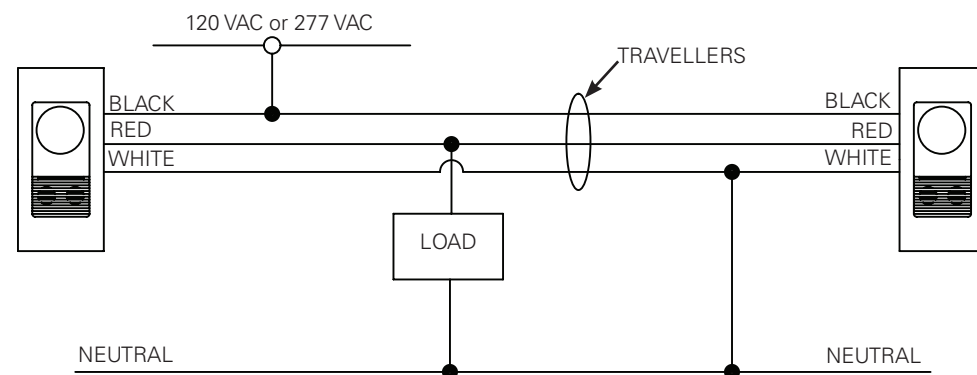

Checkout and Adjustment

Once installation is complete, restore power to the lighting circuit. Proper operation of the OSW-U-0721-MV must be verified. Controls can then be adjusted for the individual user. Adjustments should be made with the HVAC system ON.

Note: Use only insulated tools to make adjustments.

1. Adjustment controls are under the touchplate. "Time Delay" ranges from 1/4 minute (15 seconds), for installer testing, to 15 minutes. Using a small screwdriver, set "Time Delay" to 1/4 minute by turning the control completely counter clockwise until it stops at minimum setting (approximately 8 o'clock). Turn control for "Area Range" until flat edge of control is at 10 o'clock. Turn "Entry Range" until flat edge of control is at 9 o'clock.
2. Move the "Mode" switch to the "Auto" or "A" position.
3. The area of coverage can be determined by watching the LED indicator on the front of OSW-U-0721-MV while moving around the room. The LED lights only when the sensor is detecting motion. Adjust the "Area Range" control to the lowest setting that provides adequate motion detection of a person working in the room. Do not set higher than necessary.

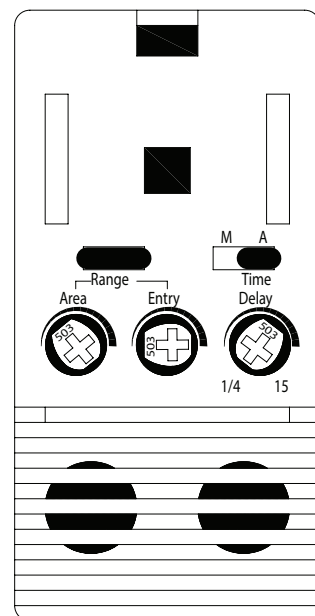

4. Leave the room. The lights should go out in approximately 15 seconds. Wait at least 12 seconds after the lights go out. Walk normally back into the room and verify that the lights turn ON automatically. If not, the "Entry Range" should be increased slightly. Do not set higher than necessary.
5. If the LED blinks or stays ON when there is no movement in the room, it is possible that the sensor is being activated by air flow from the HVAC system. Reduce the "Area Range" setting until the LED goes OFF and stays OFF with no motion.
6. If the sensor is activated by passers-by in the hallway, reduce the "Entry Range" setting.
7. Set "Time Delay" to the desired setting for normal use. If lights go out while the room is occupied, increase setting slightly until an optimum interval is obtained. Recommended time delay is usually 6-8 minutes (approximately 12 o'clock to 1 o'clock). People who remain very still for long periods may need a longer time delay.
8. If preferred, Model OSW-U-0721-MV can be set to Manual ON for maximum energy savings by moving the "Mode" switch to the "M" position. In this setting, occupant must push the touchplate to turn ON lights upon entering the room.

Override

An override jumper is located underneath the OSW-U-0721-MV touchplate. This jumper should remain in place at all times, except in the event of unit malfunction. Remove the jumper to bypass the sensor and turn the lights ON.

Troubleshooting

LED will not turn ON

Verify that the lighting circuit has power. Verify that the OSW-U-0721-MV is properly adjusted. Press the touchplate to manually turn ON the lights. If LED does not light, replace OSW-U-0721-MV.

Lights will not turn ON

If the lights will not turn ON automatically after someone enters the room, press the touchplate to see if lights will turn ON. If so, the OSW-U-0721-MV could be set to the Manual ON mode. Check under the touchplate to verify the setting. If OSW-U-0721-MV is set to Automatic ON mode, it may have been overridden by someone pressing the touchplate; allow the OSW-U-0721-MV to time out to verify normal operation. If the lights do not turn ON after pressing the touchplate, confirm that no other switches or equipment are interrupting or bypassing power to the OSW-U-0721-MV or the load. If lights still do not turn ON, replace the OSW-U-0721-MV.

Lights will not turn OFF

If the lights will not turn OFF after the time delay set, and the LED has not lit during the time period, press the touchplate to manually turn OFF the lights. If lights turn OFF, refer to items 5 and 6 above under "Checkout and Adjustment." If lights do not turn OFF, verify that the override jumper under the touchplate has not been removed. Confirm that no other switches or equipment are interrupting or bypassing power to the OSW-U-0721-MV or the load. If lights still do not turn OFF, replace the OSW-U-0721-MV.

Warranties and Limitation of Liability

Please refer to www.cooperlighting.com under the Legal section for our terms and conditions.