

DESCRIPTION

A low brightness 6-inch diameter wallwash downlight for use with A21 LED lamps. There is 45° cutoff to lamp and lamp image in the downlight portion of the distribution. Unit provides a smooth vertical wash of light without flashback. The modular housing system supports various downlight, wallwash, and lens reflectors.

Catalog #		Type
Project		
Comments		Date
Prepared by		

SPECIFICATION FEATURES

Reflector

Patented injection molded stepped kicker reflector is vacuum metallized with hardcoat finish. Positive reflector mounting pulls trim tight to ceiling. The housing is pre-set to allow reflector to be installed at 90° increments, aligned with fixture axes. Relocation of mounting screws and use of fine adjustment mechanism enable 360° adjustment. Reflectors are clearly labeled to indicate correct orientation relative to wall(s).

Trim Ring

Self flanged or molded white trim ring. Metal trim ring and rimless trim ring accessories available.

Socket Cap

One piece heat dissipating die-cast aluminum.

Universal Mounting Bracket

Accepts 1/2" EMT, C Channel, T bar fasteners and hanger bars. Provides 5" total adjustment.

Housing

Precision die-cast aluminum 1-1/2" (38mm) deep collar. Optical assembly adjusts within the housing to accommodate ceilings up to 4-1/4" (108mm) thick.

Conduit Fittings

Die-cast screw tight connectors.

Junction Box

U.L. listed for four in, four out #12 at 90°C pull through branch wiring. Pry-outs for four 1/2" and two 3/4" conduits. Access to junction box by removing reflector.

Socket

Medium base porcelain socket with nickel plated screw shell.

Insulation Detector

Self-resetting insulation detector opens circuit if insulation is improperly installed.

Options & Accessories

TRM=Metal Trim Rings to replace molded trim ring. TRR=Rimless Trim Rings for minimal flange appearance in plaster ceilings.

Labels

cULus listed, damp location.

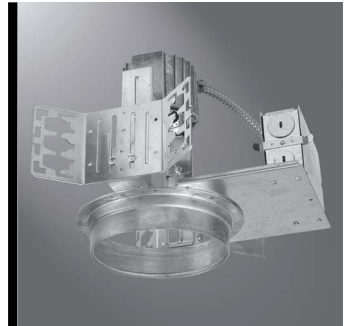

HD6
6710/6711
6720/6721
6730/6731

20W
A21

DIMENSIONS

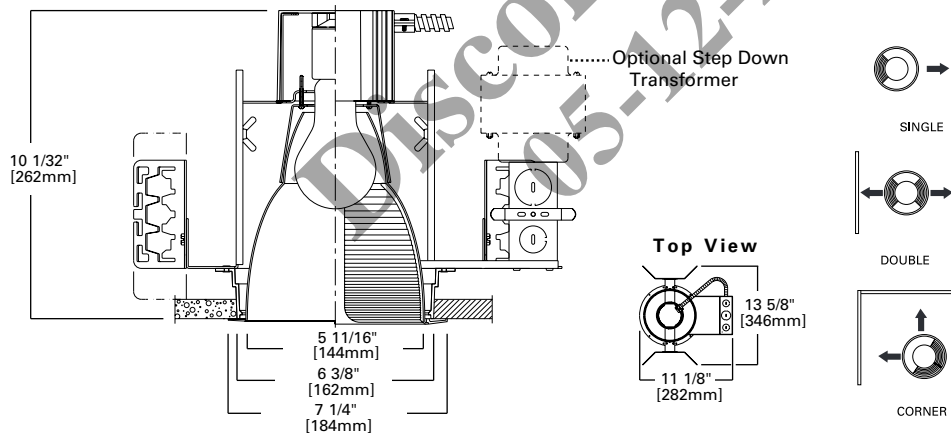

6-Inch Wall Wash Downlight

ORDERING INFORMATION

Housing	Options	Max Wattage Label	Reflector	Finish	Option	Accessories
HD6=6" Incandescent	CP=Chicago Plenum	WL20=20W	6711=Single WW, Self Flanged Reflector 6710=Single WW, Molded Trim Ring 6721=Double WW, Self Flanged Reflector 6720=Double WW, Molded Trim Ring 6731=Corner WW, Self Flanged Reflector 6730=Corner WW, Molded Trim Ring	GPH=Graphite Haze H=Semi-Specular Clear LI=Specular Clear MW=Matte White WH=Wheat WMH=Warm Haze	WF=White Painted Flanged (Self Flanged only)	H277=Step Down Transformer, 300VA Max HB26=C Channel Bar Hangers, 26" Long, Pair HB50=C Channel Bar Hangers, 50" Long, Pair TRM6=Metal Trim Ring, Specify Finish TRR6=Rimless Trim Ring, White RMB-22=Wood Joist Bar Hanger, 22" Long, Pair