



LEDALITE

by Signify

Linear Wall

ModiFly

Standalone & Continuous Runs

System Overview

These instructions review how to install ModiFly wall fixtures. ModiFly wall 2ft, 4ft, 5ft, 6ft, and 8ft modules can be installed as individual standalone units, or they can be joined together to create continuous runs. The graphic below shows the components required to install a typical run of ModiFly wall fixtures.



ModiFly wall hanger assembly***

- ModiFly wall bracket (x1)
- ModiFly locking bracket (x1)
- #8-32 x 1/2" screw (x1)
- Snap bushing (x1)
- Strain relief (x1)
- Snap plug (x1)

***Note: 2 kits required per luminaire
(3 kits required for 5ft, 6ft and 8ft)

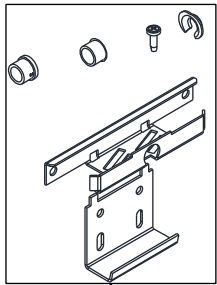

Module 2 (6ft)

Module 1 (4ft)

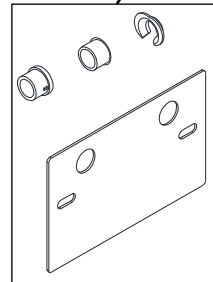

ModiFly power cover assembly

- ModiFly wall cover plate
- Snap bushing (x1)
- Strain relief (x1)
- Snap plug (x1)

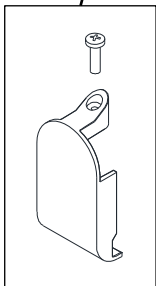

ModiFly end assembly*

- ModiFly endcap insert
- #6-32 x 7/16" screw

*Note: 2 kits required for each run
(one for each end).

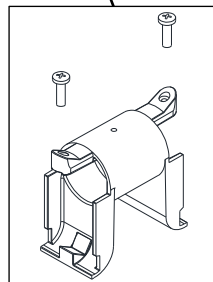

ModiFly straight joint assembly**

- ModiFly continuous run joint
- #6-32 x 7/16" screw (x2)

**Note: 1 kit required for each in-run joint.

TOOLS REQUIRED: Phillips screwdriver, Flat-head screwdriver, #2 Robertson screwdriver (optional)

This equipment has been tested and found to comply with the limits for a Class A digital device, pursuant to part 15 of the FCC Rules. These limits are designed to provide reasonable protection against harmful interference when the equipment is operated in a commercial environment. This equipment generates, uses, and can radiate radio frequency energy and, if not installed and used in accordance with the instruction manual, may cause harmful interference to radio communications. Operation of this equipment in a residential area is likely to cause harmful interference in which case the user will be required to correct the interference at his own expense.



Warning! Shock Hazard!

IMPORTANT:
Disconnect or turn off power before attempting any installation, service or maintenance.



Warning! Shock Hazard!

Fixture must be connected to building ground via the provided ground wire before re-connecting to mains power supply.



Installation Notes

Arrange boxed fixtures on floor in specified mounting locations, based on supplied layout drawings. Remove fixtures from boxes.

Install all ceiling mounting components and vertical aircraft cables using separate installation instruction for Aircraft Cable Mounting (supplied).



ATTENTION: Install in accordance with local and national building and electric codes.

Module Lengths and Standalone Mounting Points

ModiFly wall systems come in 2ft, 4ft, 5ft, 6ft and 8ft modules. Standalone mounting points and overall module lengths are shown below.

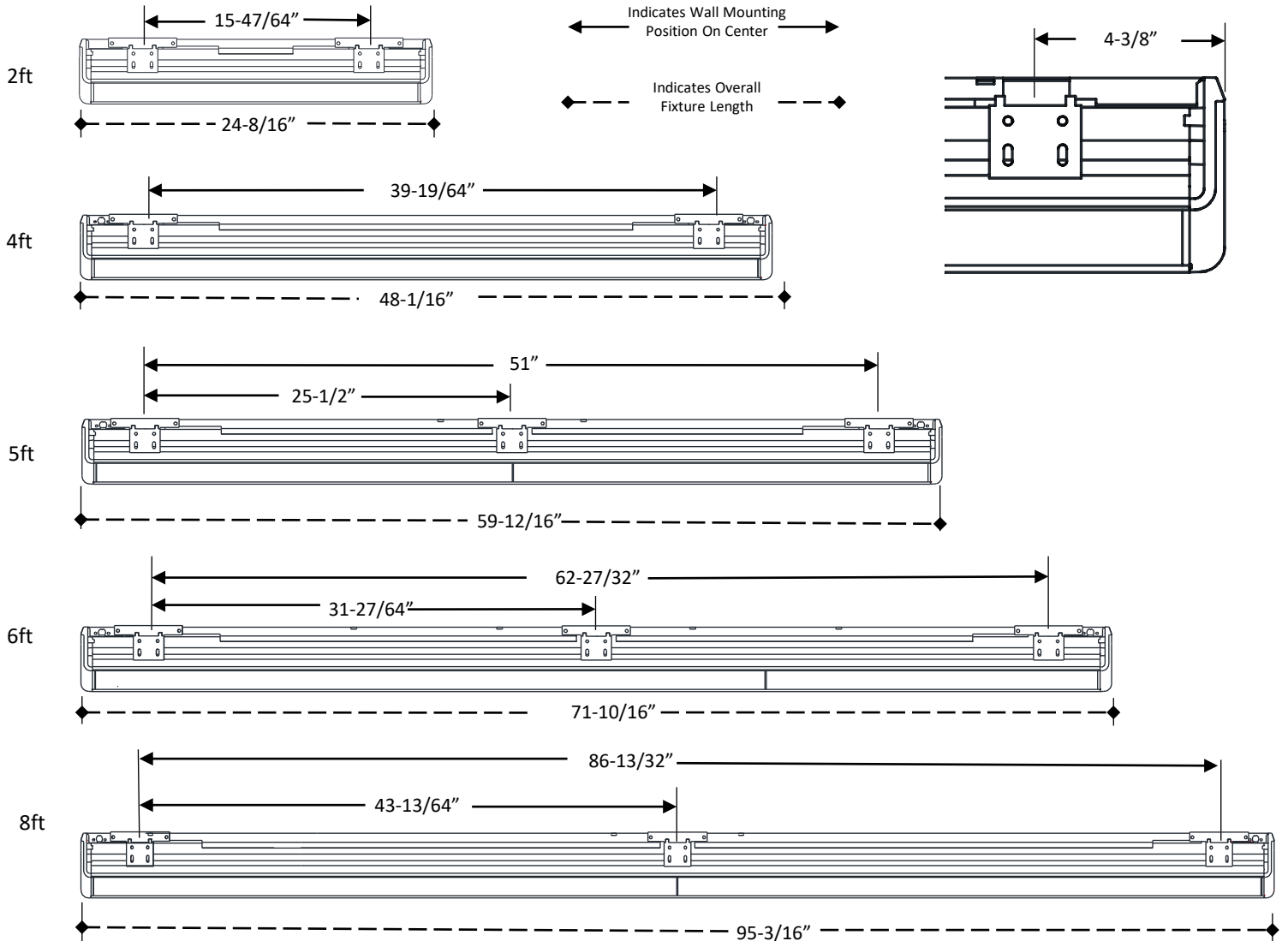

Continuous Run

For continuous runs the fixture is mounted the same as standalone lengths. The space between the straight joint to the next fixture mount bracket on center is shown below.

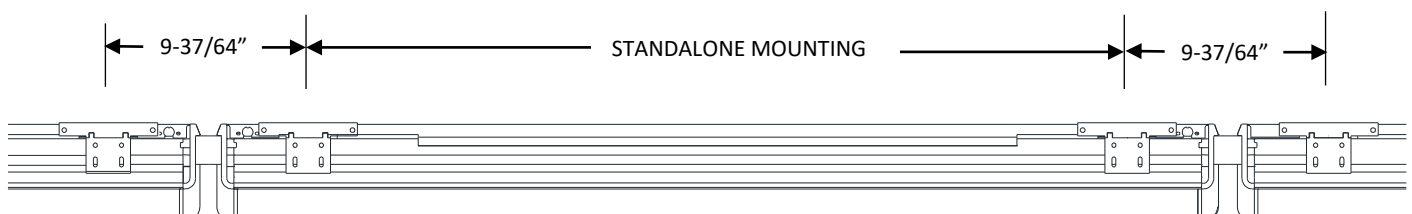

1 Prepare fixtures/install mounting components

Arrange boxed fixtures on floor in specified mounting locations. Remove fixtures from boxes. Install all wall mounting components (supplied).

NOTE: If conditions are dusty/dirty, recommended practice is to leave fixtures in their plastic bags until ready to mount.

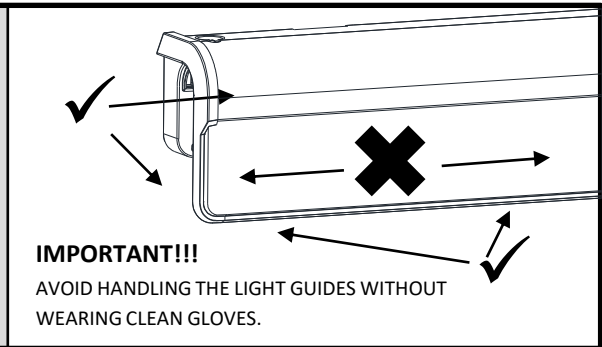

2 Plan wall mount bracket locations

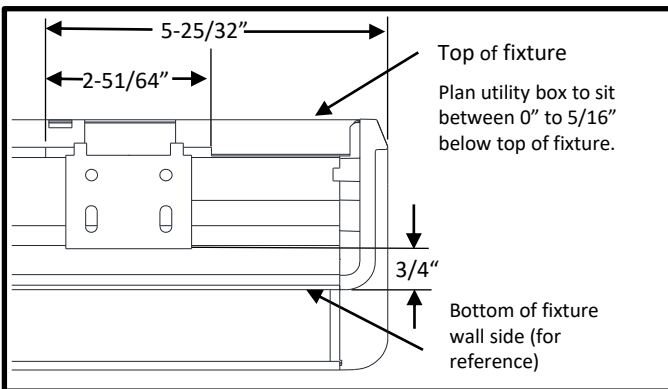

Determine wall mount bracket location based on the allowable distance from fixture ends to brackets and also factoring in site conditions (location of structural members).

Each 2ft and 4ft fixture requires two brackets and each 5ft, 6ft, and 8ft requires three brackets. Refer to Module Lengths and Standalone Mounting Points on page 2.

3 Install utility box and cover plate

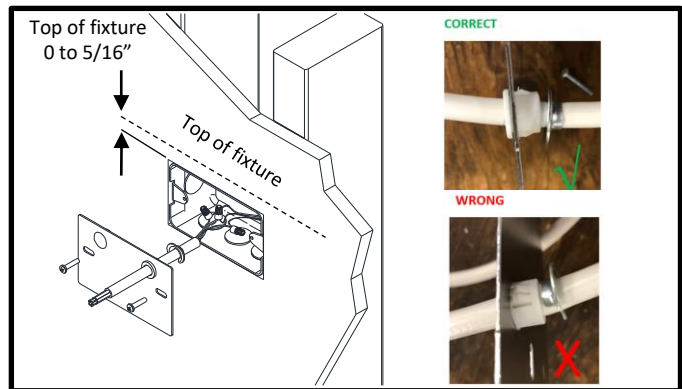

Determine power feed location and install 2"x4" utility box (supplied by others) parallel with fixture. Complete electrical connections at box with supplied power cord.

Crimp supplied strain relief onto power cord insulation (recommended Heyco Tool PN0019(R12)). Attach cover using two screws supplied by others. Plug open hole with Heyco plug.

4 Install wall mount brackets

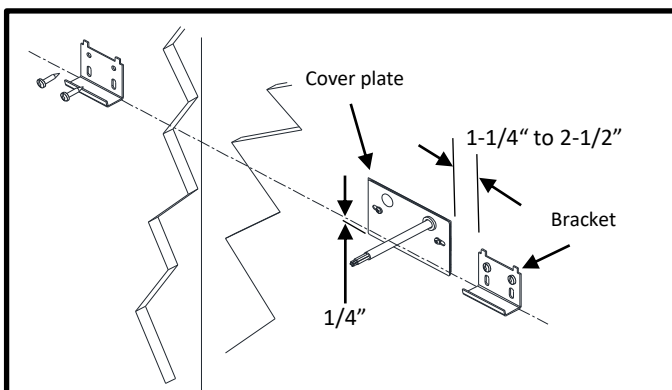

Install ModiFly wall mount brackets to wall structure using appropriate fasteners (BY OTHERS). Note bottom of installed fixture on the wall side will sit approx. 3/4" below bottom of bracket. Bottom edge of wall bracket to be located approx. 1/4" with bottom edge of cover plate.

Locate bracket between 1-1/2" to 2-3/4" from edge of cover plate.

5 Remove top cover

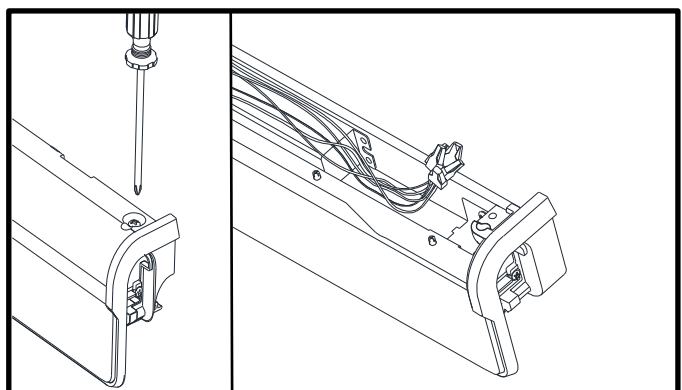

Remove top cap of fixture to allow for power access. Two screws to remove with a Phillips screwdriver or Robertson #2. One on each end.

6 Install fixture on wall bracket

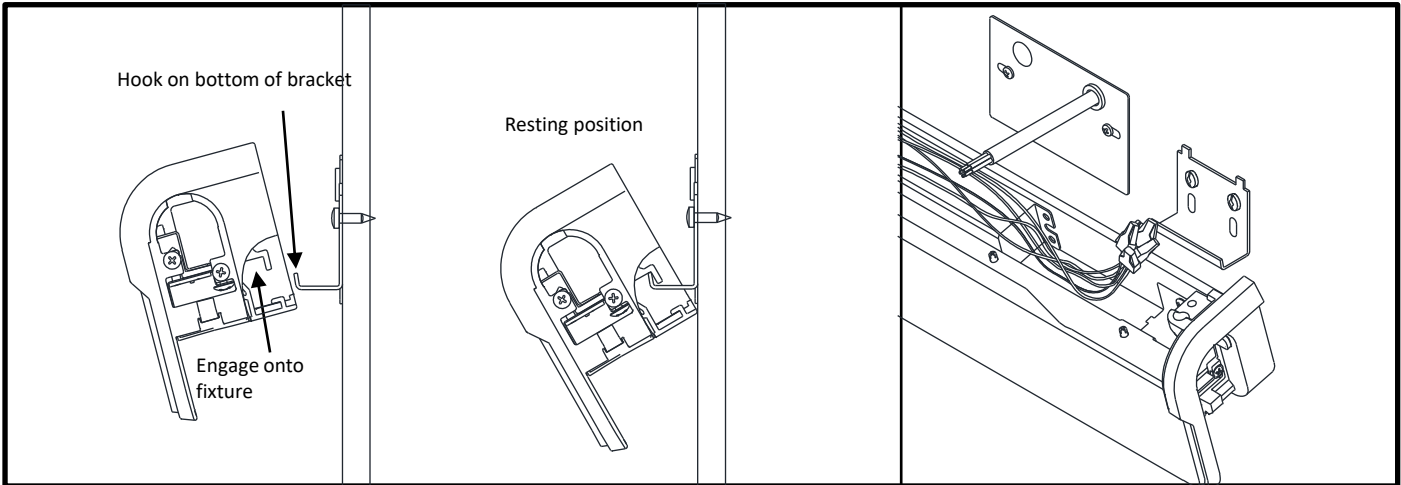

With two people, raise fixture into position and engage it on bracket (hook) located on bottom of brackets. Let the fixture rotate down into resting position.

POWER LOCATIONS: When engaging fixture on mounting brackets, guide the installed power cord over fixture so not to pinch it between the fixture and the wall.

7 Install locking brackets and make power connections

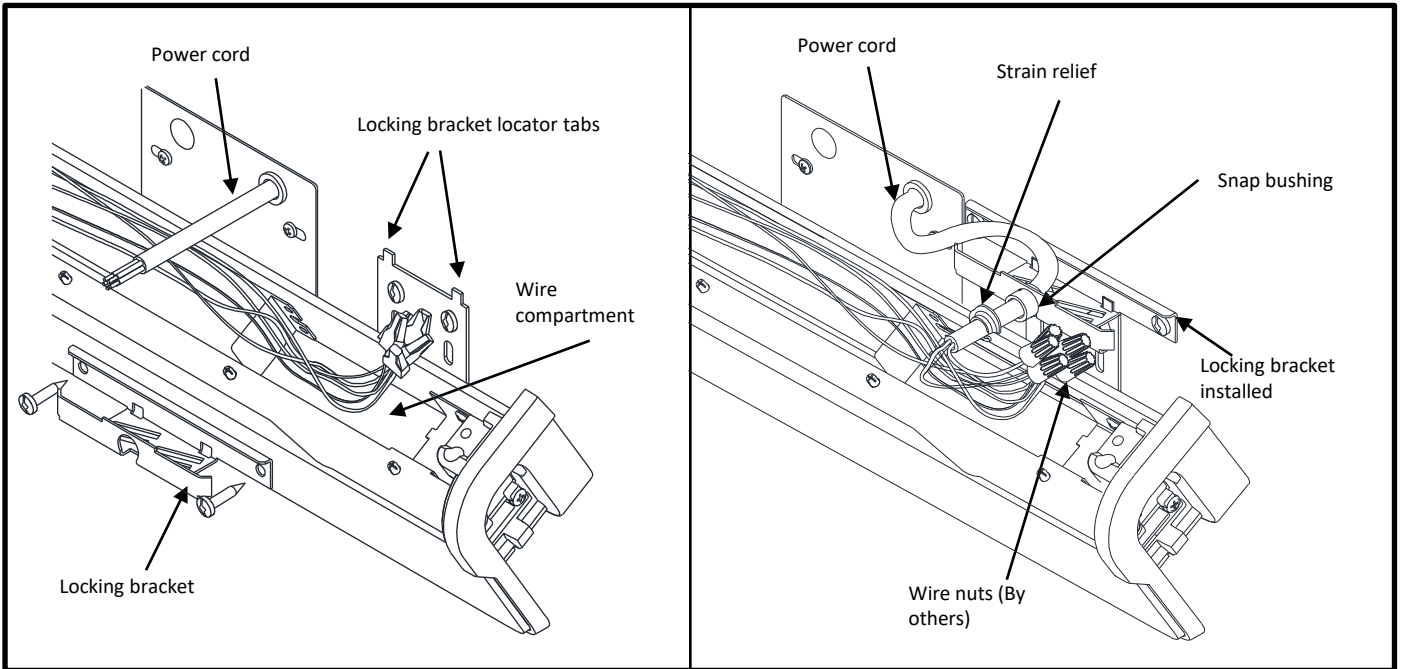

Install locking bracket to wall structure using appropriate fasteners (BY OTHERS). The locking bracket can be located using the locator tabs on top of the wall bracket.

Install bushing into locking bracket and feed the power cord through locking bracket. Crimp supplied strain relief onto power cord insulation (recommend Heyco Tool PN0019(R12)). Complete necessary electrical connections (by others) in compliance with local codes. Push the wires and connectors back down into the wire compartment when complete.

8 Secure fixture with top locking bracket and install top cap

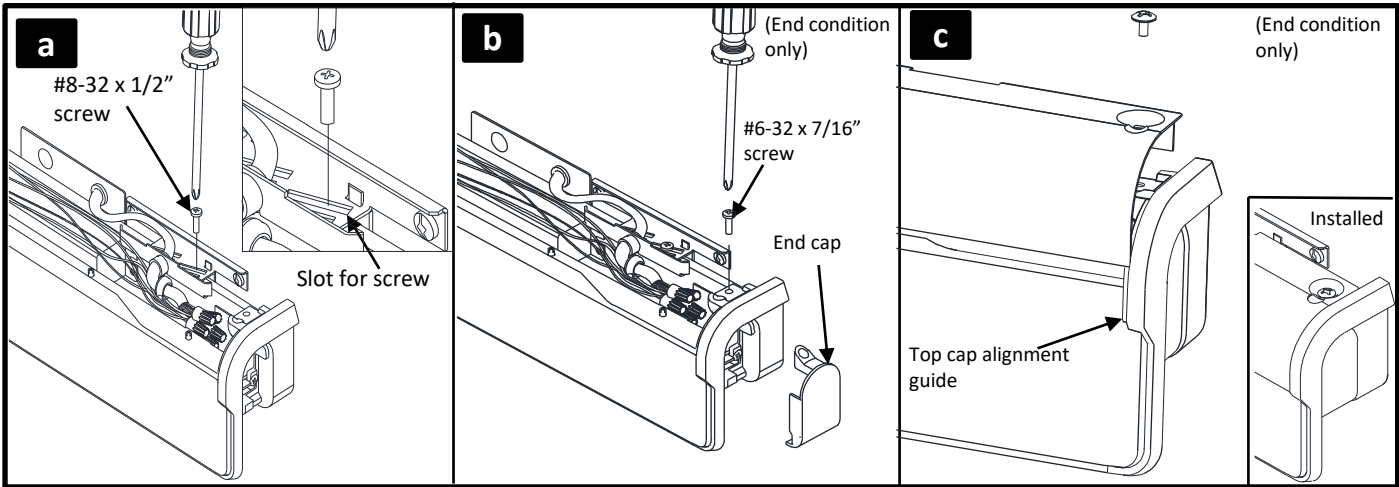

Level fixture and mount to locking bracket with 8-32 x 1/2" screw with a Phillips screwdriver. Install end cap and secure with #6-32 x 7/16" screw provided in end cap kit with a Phillips screwdriver. Re-install the top cap.

IMPORTANT: Do not over-tighten endcap and joiner screws. Ledalite recommends tightening by hand.

9 Continuous Run

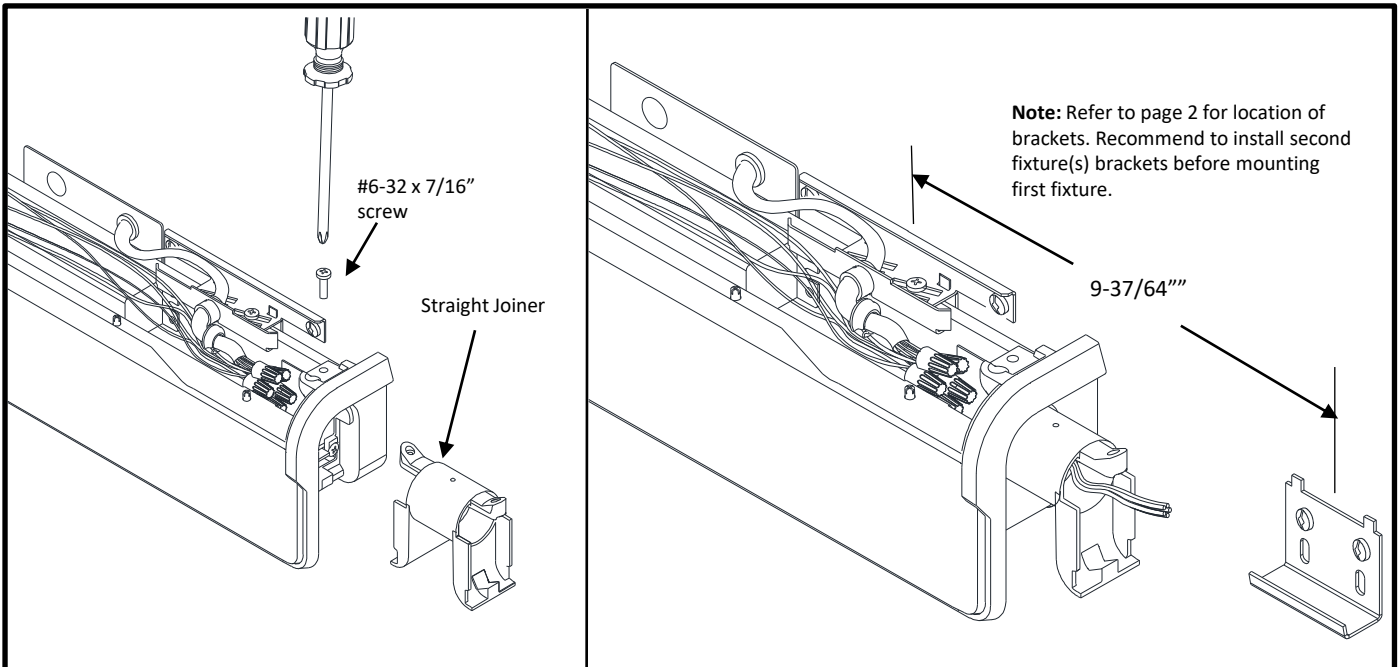

Continuous run must have wall bracket installed for adjacent fixtures. Refer to page 2 for location of brackets.

Install straight joiner to installed fixture and secure with #6-32 x 7/16" screw provided with a Phillips screwdriver. Refer to step 8b. Once installed feed wires from mounted fixture through the straight joint. **Ensure continuous run joint is seated properly in the fixture.**

10 Raise fixture on straight joint and Feed wires through

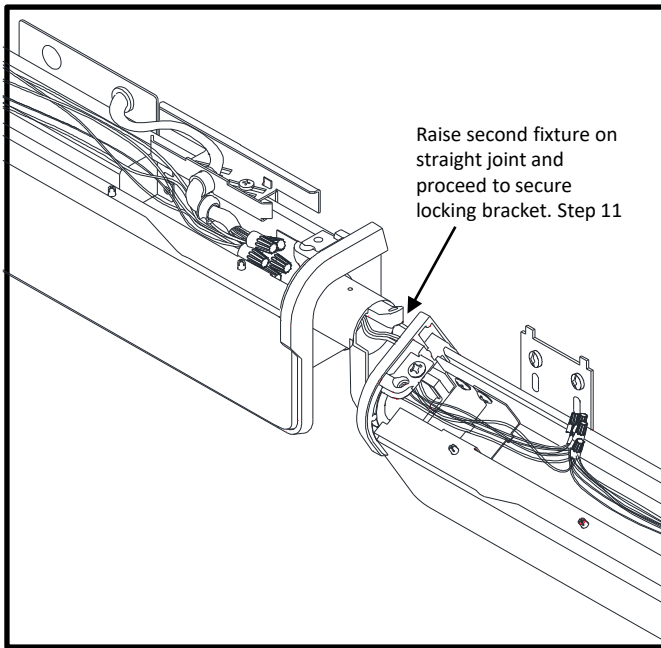

Raise fixture and feed wires through straight into second fixture.

11 Secure fixture on straight joint and install Locking bracket. Complete electrical connections

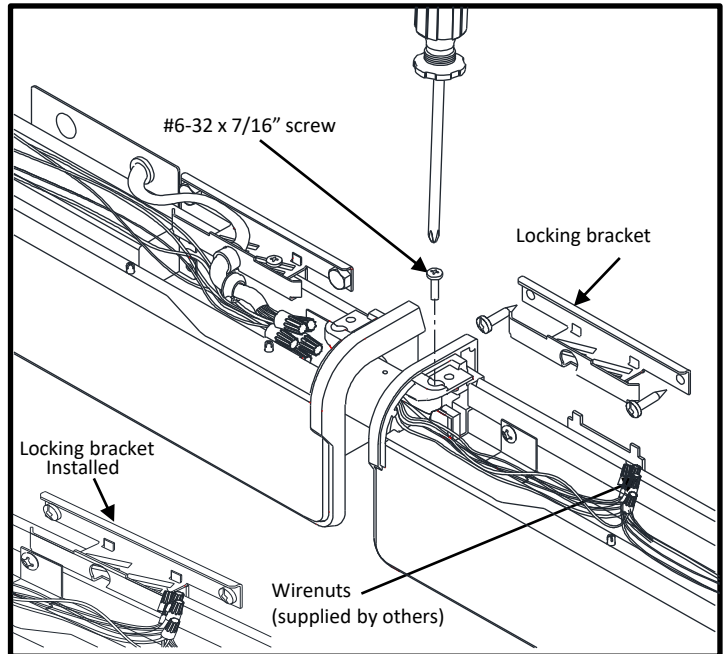

Secure fixture to straight joint with provided #6-32 x 7/16" screw. Install locking bracket, see step 11 for reference.

12 Install top cap(s)

Repeat steps 9 to 11 for next fixture(s) in the run.

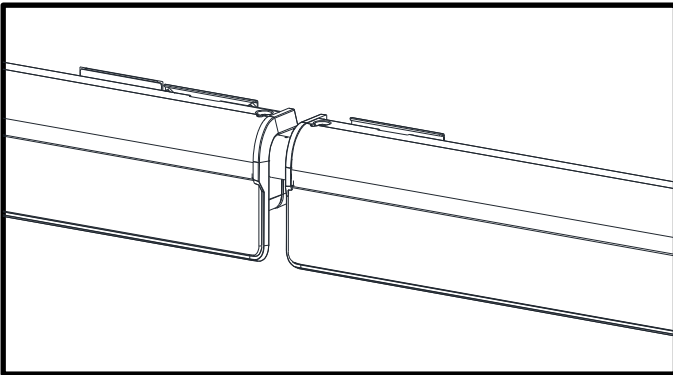

13 Leveling and Cleanup

- Level row by adjustments at the locking bracket.
- Wipe light guide panel clean if required – ensuring to not introduce scratches.

Sensors in Rows

Single Sensor Controlling Whole Row

1. Purple & brown (or purple & grey/pink) control wires **MUST** be connected between fixtures.

Note:

- A maximum of 8 drivers can be wired to one sensor; confirm fixture driver count with factory.

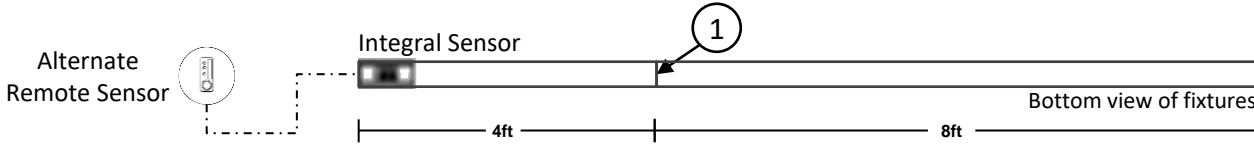

Multiple Sensors Controlling Separate Zones in a Row

2. Purple & brown (or purple & grey/pink) control wires **MUST NOT** be connected between zones.

Notes:

- A maximum of 8 drivers can be wired to one sensor; confirm fixture driver count with factory.
- Only one sensor is allowed on a wired zone. (Sensors can be paired together wirelessly via a mobile app).

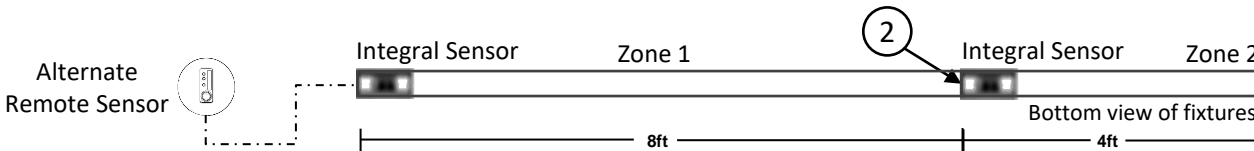

Sensor Spacing

- For correct operation, sensors should be placed a minimum distance of 8ft apart.
- Wireless sensors should be placed no further than 40ft apart for good wireless signal connection.

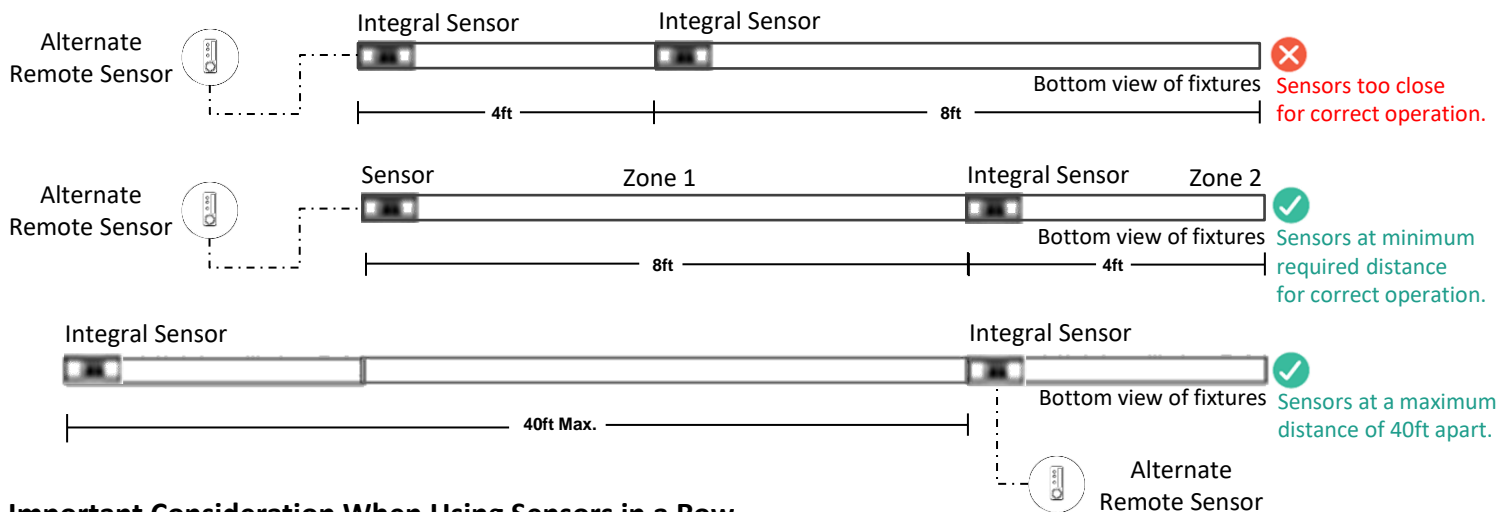

Important Consideration When Using Sensors in a Row

- For fixtures with wireless sensors (CS, SB or RA options):
DO NOT connect fixture purple & brown (or purple & grey/pink) control wires to an external dimming switch. Fixture mains wiring should not be connected to a circuit with an external on/off switch.
- For best aesthetic condition, place sensors at ends of row only so as not to break the continuous lens.
- For better occupancy coverage in longer rows, sensors may be placed mid run, but keep in mind this will break the continuous lens into discrete sections. Alternatively, remote sensor may be used, note the same wiring rules will apply.

! ATTENTION: Install in accordance with national and local building and electrical codes.

Occupancy Sensor Coverage:

Note: Longer dimension of detection area (Y1, Y2) is parallel to longer dimension of the luminaire.

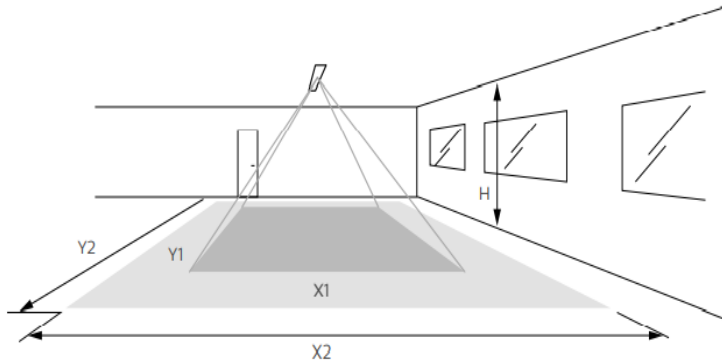

Height	Minor movement		Major movement	
h	X1	Y1	X2	Y2
2.4 m (7.9 ft)	1.9 m (6.2 ft)	2.9 m (9.5 ft)	2.9 m (9.5 ft)	4.3 m (14.1 ft)
3 m (9.8 ft)	2.4 m (7.9 ft)	3.6 m (11.8 ft)	3.6 m (11.8 ft)	5.4 m (17.7 ft)

The detection area for the movement sensor can be roughly divided into two parts:

- Minor movement (person moving $\leq 3\text{ft/s}$ or 0.9m/s).
- Major movement (person moving $\geq 3\text{ft/s}$ or 0.9m/s).

Daylight sensor

The light sensor measures the total amount of light in a circular field of approximately 80% of the PIR detection area. The following aspects should be observed during installation:

- Minimum distance from the window $\geq 2\text{ft}$ (0.6m).
- Prevent light reflections from outside entering the sensor (for example sunlight reflection on a car hood) as this will lead to incorrect light regulation.

As a guideline the formula $0.72 \times H$ can be used to calculate the minimum distance between the window and sensor whereby H is the height from the bottom of the window to the sensor.

Photosensor spatial response

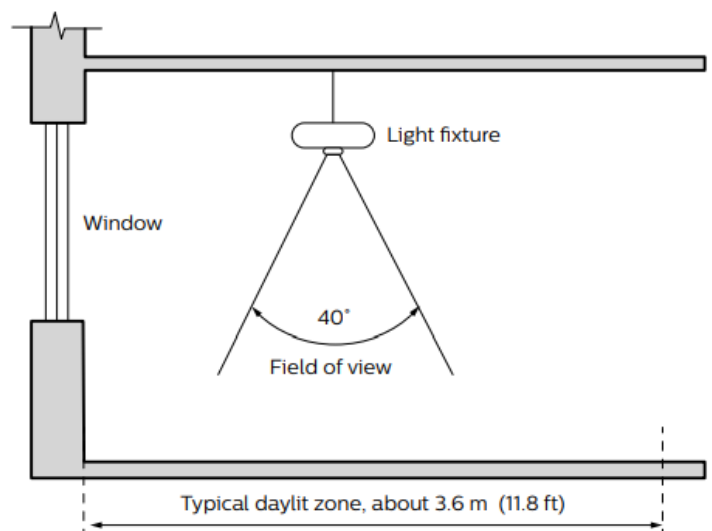

! ATTENTION: Install in accordance with local and national building and electric codes.

