

CHLORIDE

Rhyno Series

Industrial Emergency Unit



INSTALLATION AND OPERATING INSTRUCTIONS

IMPORTANT SAFEGUARDS

When using electrical equipment, basic safety precautions should always be followed, including the following:

READ AND FOLLOW ALL SAFETY INSTRUCTIONS

All servicing should be performed by qualified personnel only.

Equipment should be mounted in locations and at heights where it will not be readily subjected to tampering by unauthorized personnel.

The use of accessory equipment not recommended by the manufacturer may cause an unsafe condition.

Do not use this equipment for other than intended use.

Do not let supply cords touch hot surfaces.

Do not mount near gas or electric heaters.

CAUTION: Halogen cycle lamp(s) are used in this equipment. To avoid shattering: Do not operate lamp in excess of rated voltage, protect lamp against abrasion and scratches and against liquids when lamp is operating, dispose of lamp with care.

Halogen cycle lamps operate at high temperatures. Do not store or place flammable materials near lamp.

CAUTION: “To avoid electrical overload, total connected lamp load (factory and field installed) should not exceed output rating”.

SAVE THESE INSTRUCTIONS

WARNING – Shut off AC power to branch circuits to which units will be connected. All wiring should be per N.E.C. Articles 501-4(b) and local codes.

To maintain warranty, equipment with batteries must be installed or placed on charge within prescribed period after shipment.

GENERAL INSTRUCTIONS

- 1) Begin the installation process by securing the mounting plate.
- 2) The slotted, circular keyways can be used to secure the mounting plate to a standard junction box. The junction box must be secured sufficiently to handle the weight of the unit. Additionally, four slotted vertical keyways may be used to attach the mounting plate to independent anchor supports. If wall mounted, run wires through center hole of mounting plate in preparation for unit wiring.

CHLORIDE

Signify North America Corporation
200 Franklin Square Drive
Somerset, NJ 08873, USA
Phone: 855-486-2216
www.chloride-lighting.com

Signify Canada Ltd./Signify Canada Ltée.
281 Hillmount Road,
Markham, ON, Canada L6C 2S3
Phone: 800-668-9008

July 2018
443580514461

- 3) If the unit is to be mounted to poles or columns, use the optional strapping kit (ordered separately).

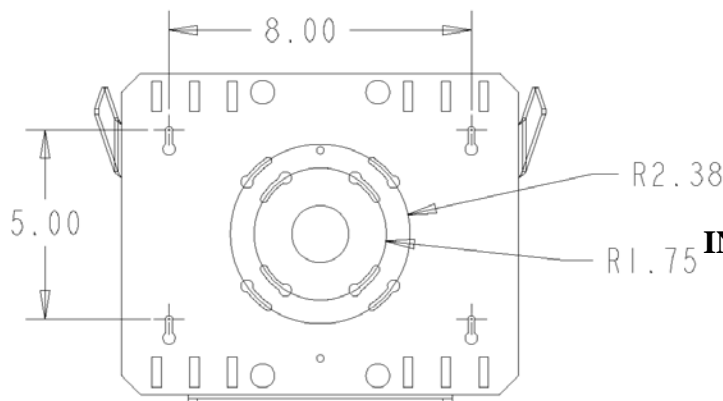

- 4) Once mounting plate is installed, the unit is ready for installation.

To aid in installation, the cover may be removed. To remove cover, disconnect cover membrane switch harness. Open cover 90° and lift. Reverse procedure to return cover to unit. For standard and damp location units that will not see direct water spray, the unit can be wired from the back. Prepare unit by removing circular knockout in the center of the back housing. The unit is now installed by placing the back housing on the two ears of the mounting plate and pivot unit down onto mounting plate. Route wires through hole in the back housing as the unit is pivoted into place.

NOTE: Wet location units must not have the back knockout removed as water will enter the unit. Use U/L listed Wet Location approved conduit or wire cord fittings using removable knockouts on side / top.

- 5) Unit mounting is completed by installing two screws and rubber washers through the back housing into the mounting plate for security.

INSTALLING BATTERIES

1. Units ship without batteries installed. Unit batteries are shipped separately. Battery wiring harnesses are already connected to PCB assembly. Connection of harness to batteries is required.
2. Install and wire batteries as appropriate. (See Page 6-7 for battery configurations)
3. Tighten straps to secure batteries inside unit.

INSTALLING BATTERIES ON UNITS WITH HEATERS

1. When installing batteries on units with the optional heater, the black foam heater pad is to be placed first in the battery compartment with the rectangular flap toward the back of the unit. Do not remove adhesive backing. The orange battery heater is placed on top of the heater insulating pad.

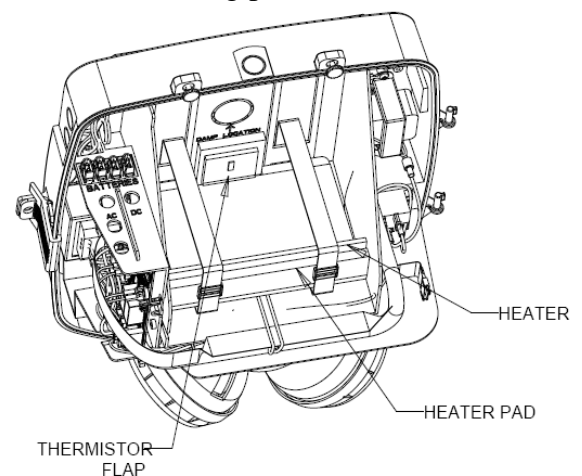

NICAD

2. Secure battery, heater and heater insulating pad with Velcro strap as shown.
3. On 6V 50W Nicad and 12V 50W Nicad units, the leading edge of the heater pad and heater is wrapped around the front of the battery pack.
4. Note: Ensure that the thermistor flap is between the insulating pad and the battery for accurate battery temperature measurements.
5. Completed unit shown.

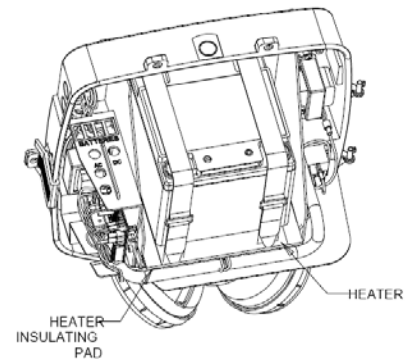
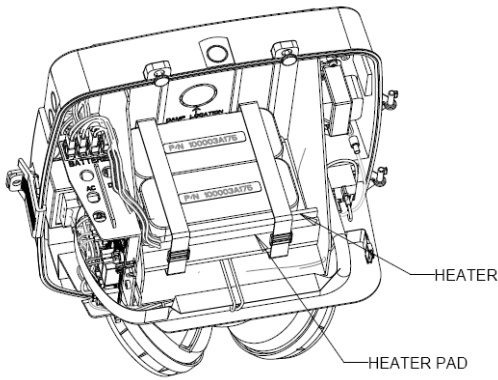

LEAD

- For 12V 100W lead units, the battery insulating pad and heater remain flat. Place the battery above the heater and secure with Velcro straps.

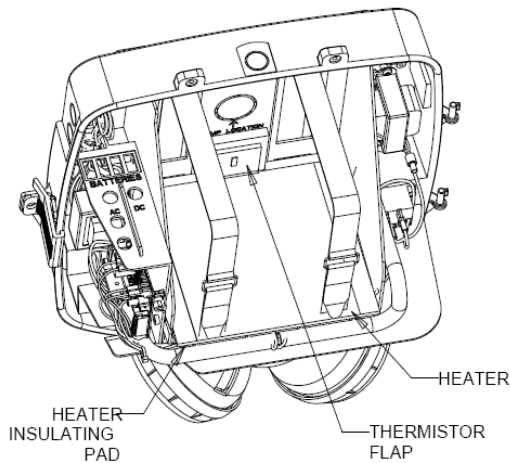

- Note: Ensure thermistor flap is between the insulating pad and the battery for accurate battery temperature measurements.
- Completed assembly shown.

HOOKUP INSTRUCTIONS

Standard Units:

Connect A.C. service to unit charger leads:
 Blue = 277 VAC
 Black = 120 VAC
 White = Common
 Green = Ground

Units with Battery Heater (EE & CA):

Connect A.C. service to unit charger transformer *and* heater transformer leads:
 Blue = 277V
 Black = 120V
 White = Common
 Green = Ground

- Connect remote lamps, if applicable, to orange and yellow flying leads connected to RL+ and RL- respectively. Ensure total unit load (including internal lamps) does not exceed unit rating.
- Adjust head(s) to illuminate desired area(s).
- Close cover and latch. Ensure electrical wires and membrane switch cable remain inside unit and that the cover does not pinch wires when closed. Hand-tighten four thumb nuts to finalize cover closure. Thumb screws must be used and tightened to maintain a good environmental seal.

CHLORIDE

Signify North America Corporation
 200 Franklin Square Drive
 Somerset, NJ 08873, USA
 Phone: 855-486-2216
www.chloride-lighting.com

Signify Canada Ltd./Signify Canada Ltée.
 281 Hillmount Road,
 Markham, ON, Canada L6C 2S3
 Phone: 800-668-9008

July 2018
 443580514461

Self Diagnostic System Operation – Emergency Light or EXIT Sign Products

Normal Power Up Sequence

At power up the red and green LED indicators will alternately flash for one to two seconds. Next the product will execute a “Power Up Quick Test” causing the green LED indicator to flash rapidly. If any faults are detected during the “Power Up Quick Test” these will be evident by a flashing red LED indicator. If the audible diagnostic option has been ordered, the flashing red LED will be accompanied by a simultaneous beeping tone. **(Note: A continuous rapid alternating Red/Green flash with rapid beeping tone indicates 277V applied to 120V input lead. TURN OFF POWER IMMEDIATELY!)**

Emergency Operation

Emergency operation occurs when AC power fails. The product remains in emergency operation until AC power is restored or battery capacity is depleted. During emergency operation both red and green LED indicators are disabled.

User Interface

Green LED indicator

- Slow Flash/Continuous ON = AC power present; normal operating condition
- Rapid Flash = product performing an automatic or manually initiated diagnostic test

Red LED indicator

- Single Flash = battery fault
- Two Flashes = lamp failure (light bar failure – EXIT signs)
- Three Flashes = charger fault
- Four Flashes = transfer fault

(If more than one fault condition is present simultaneously, the red LED will flash the indication pattern for each fault independently then repeat the cycle.)

Pushbutton Test Switch

- Long Press (longer than 0.5sec) transfers product to emergency operation during time the button is pressed.
- Short Press initiates self diagnostic activities as follows:
 - One Press cancels diagnostic test presently running.
 - Two Presses starts a one minute diagnostic test.
 - Three Presses starts a 90 minute diagnostic test.
 - Four Presses conducts a lamp load calibration (emergency light products only).
 - Seven Presses initiates a system reset.

(Note: the microprocessor will allow up to seven, one minute diagnostic tests within the first 24 hours of operation. Allow 24 hours of charging before performing any long duration testing.)

Buzzer (optional)– Sounds in unison with the flashing red LED if a fault condition is present. Buzzer may be silenced for up to 196 hours by a short press of either the test switch or the optional IR remote control device “silence” button. Correcting fault condition will cancel fault notification. Lamp failure indication requires a manually activated diagnostic test after lamp replacement to cancel notification.

IR Remote Control (optional)- is a hand held device that allows remote activation of diagnostic testing and silencing of the optional buzzer during fault conditions.

CHLORIDE

Signify North America Corporation
200 Franklin Square Drive
Somerset, NJ 08873, USA
Phone: 855-486-2216
www.chloride-lighting.com

Signify Canada Ltd./Signify Canada Ltée.
281 Hillmount Road,
Markham, ON, Canada L6C 2S3
Phone: 800-668-9008

July 2018
443580514461



**SILENCE
ALARM**



**1 MINUTE
TEST**



**30 MINUTE
TEST**



**90 MINUTE
TEST**



CANCEL

CHLORIDE



Intelli-Charge

OPTIONAL REMOTE CONTROL

Front

Press appropriate button to perform the indicated test or silence the audible alarm.

Cancel stops any test currently in process.

System Reset: Two presses of "SILENCE ALARM" button followed by two presses of "CANCEL" button.

Interpretation of Flashing Indicator lights on Equipment:

Green LED Indicator:

- Steady On - Normal
- Slow Flash - Battery Charging
- Fast Flash - Unit is self-testing

Red LED Indicator:

- Single Flash - Battery Fault
- Double Flash - Lamp Failure
- Triple Flash - Charger Fault
- Quad Flash - Emergency Transfer Failure

Red and Green LED indicators flashing together:

- Slow Flashing - Low Line Voltage
- Fast Flashing - High Line Voltage

Unit Equipment Lamp Calibration

Press "Silence Alarm" twice followed by one press of "Cancel" and one press of "Silence Alarm"
For Service Call (910)259-1000

Back

Explanation of indicator light flash sequences.

Refer to Table 2 above for further information.

CHLORIDE

Signify North America Corporation
200 Franklin Square Drive
Somerset, NJ 08873, USA
Phone: 855-486-2216
www.chloride-lighting.com

Signify Canada Ltd./Signify Canada Ltée.
281 Hillmount Road,
Markham, ON, Canada L6C 2S3
Phone: 800-668-9008

July 2018
443580514461

BATTERY HOOKUP DIAGRAMS

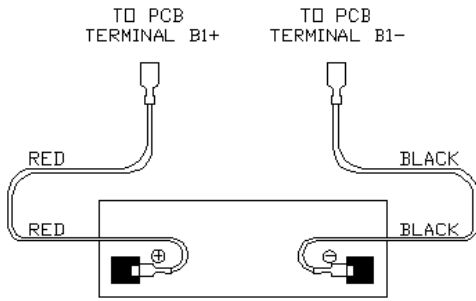

6V 25W LEAD

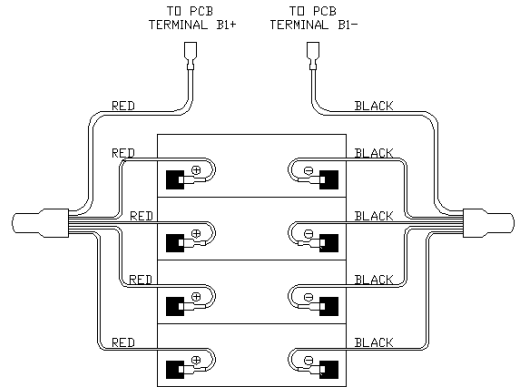

6V 100W LEAD

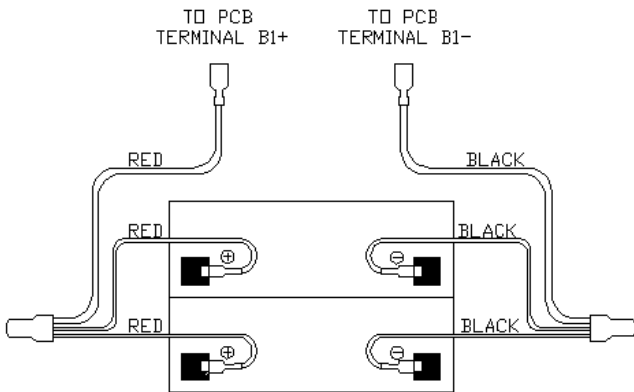

6V 50W LEAD

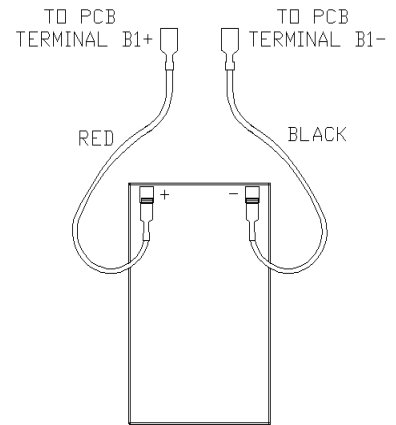

12V 50W LEAD

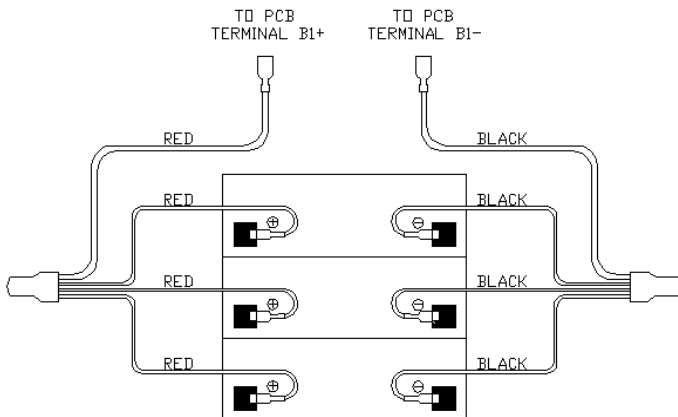

6V 75W LEAD

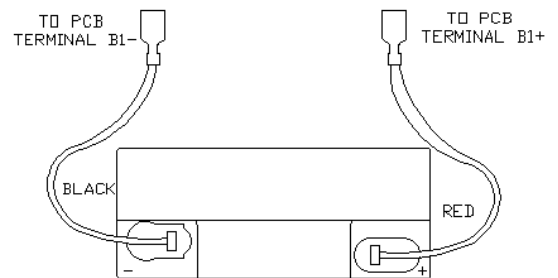

12V 75W LEAD

CHLORIDE

Signify North America Corporation
 200 Franklin Square Drive
 Somerset, NJ 08873, USA
 Phone: 855-486-2216
www.chloride-lighting.com

Signify Canada Ltd./Signify Canada Ltée.
 281 Hillmount Road,
 Markham, ON, Canada L6C 2S3
 Phone: 800-668-9008

July 2018
 443580514461

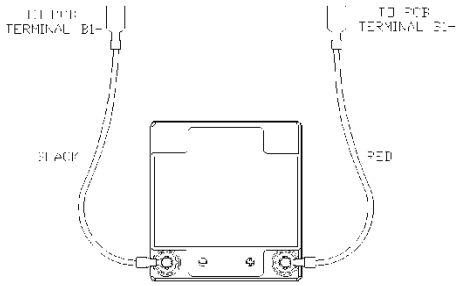

12V 100W EE & HA LEAD

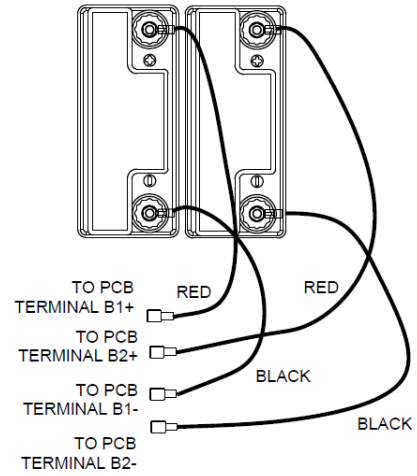

12V 150W EE & HA LEAD

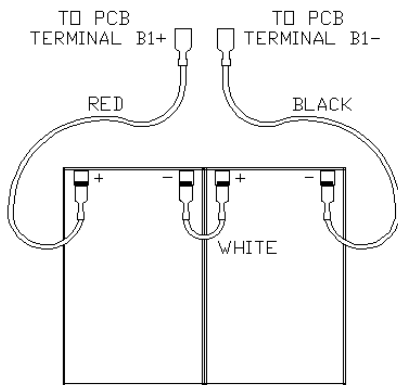

24V 100W LEAD

NICAD BATTERY HOOKUP

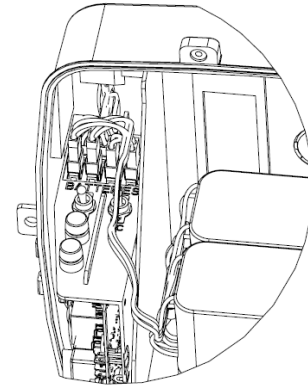

6V 50W NICAD

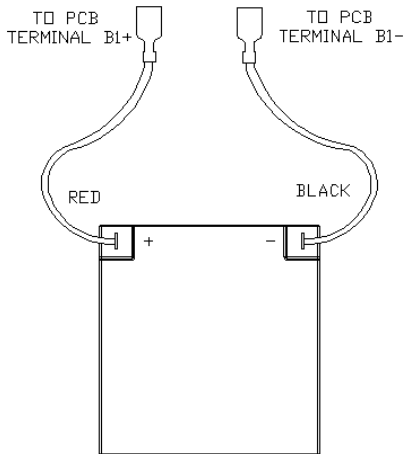

12V 100W & 150W LEAD

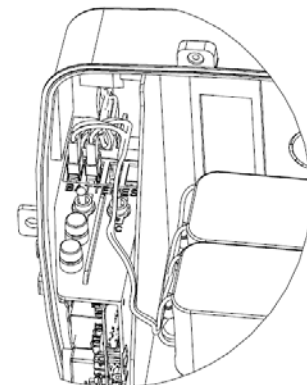

12V 50W NICAD