



by Signify

# Linear Suspended

ModiFly

Standalone & Continuous Runs



## System Overview

These instructions review how to install ModiFly suspended fixtures. ModiFly 2ft, 4ft, 5ft, 6ft, and 8ft modules can be installed as individual standalone units, or they can be joined together to create continuous runs. The graphic below shows the components required to install a typical run of ModiFly suspended fixtures.

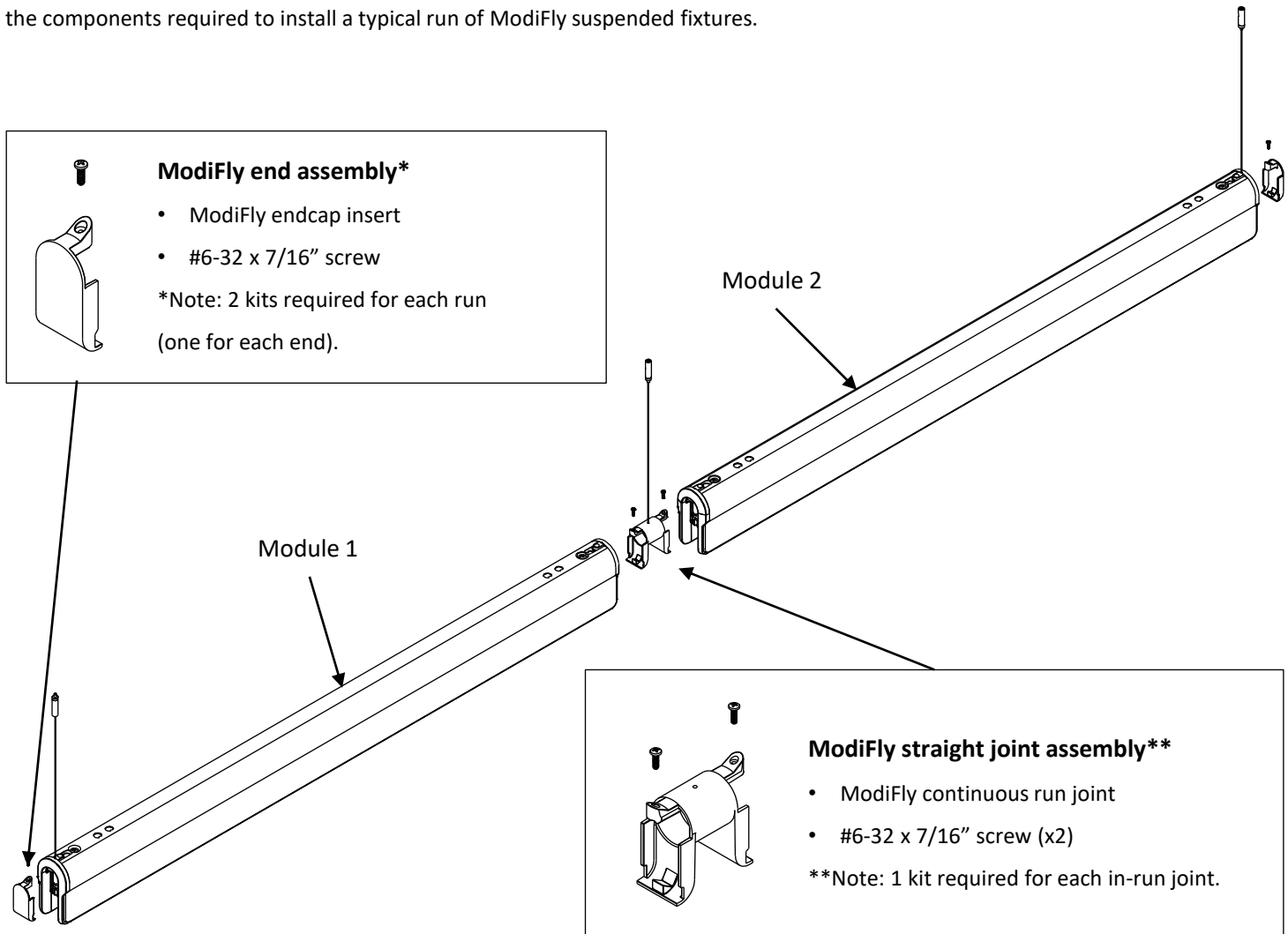

**TOOLS REQUIRED:** Phillips screwdriver, Flat-head screwdriver, #2 Robertson screwdriver (optional)

*This equipment has been tested and found to comply with the limits for a Class A digital device, pursuant to part 15 of the FCC Rules. These limits are designed to provide reasonable protection against harmful interference when the equipment is operated in a commercial environment. This equipment generates, uses, and can radiate radio frequency energy and, if not installed and used in accordance with the instruction manual, may cause harmful interference to radio communications. Operation of this equipment in a residential area is likely to cause harmful interference in which case the user will be required to correct the interference at his own expense.*



### Warning! Shock Hazard!

**IMPORTANT:**  
Disconnect or turn off power before attempting any installation, service or maintenance.



### Warning! Shock Hazard!

Fixture must be connected to building ground via the provided ground wire before re-connecting to mains power supply.



### Installation Notes

Arrange boxed fixtures on floor in specified mounting locations, based on supplied layout drawings. Remove fixtures from boxes.

Install all ceiling mounting components and vertical aircraft cables using separate installation instruction for Aircraft Cable Mounting (supplied).



**ATTENTION: Install in accordance with local and national building and electric codes.**

### Module Lengths and Standalone Mounting Points

ModiFly suspended systems come in 2ft, 4ft, 5ft, 6ft and 8ft modules. Standalone mounting points and overall module lengths are shown below.

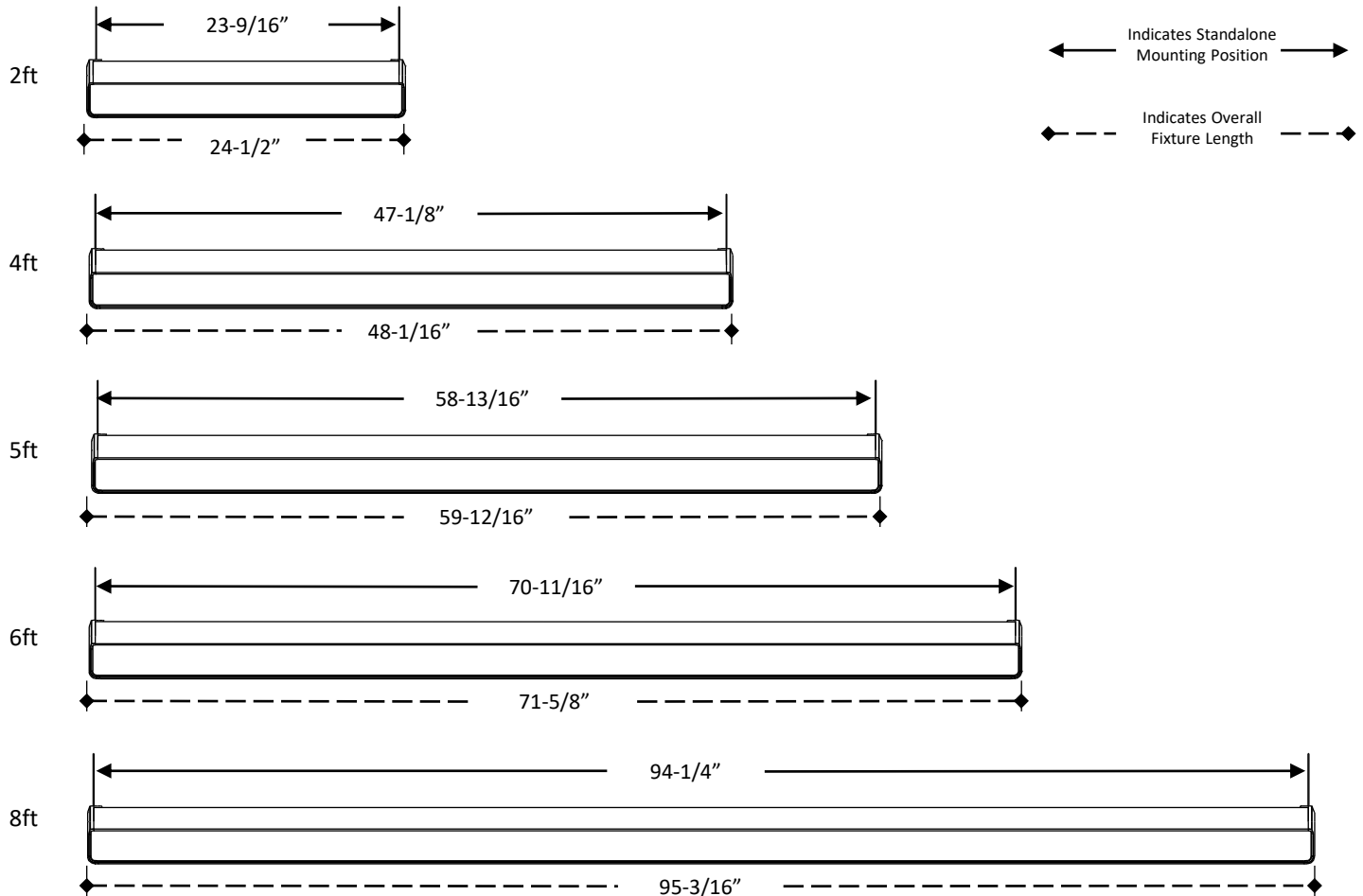

### Continuous Run

For continuous runs the fixture is mounted from the continuous run joint supplied in the straight joint assembly.

Continuous runs with 8ft modules are designed to mount on grid.

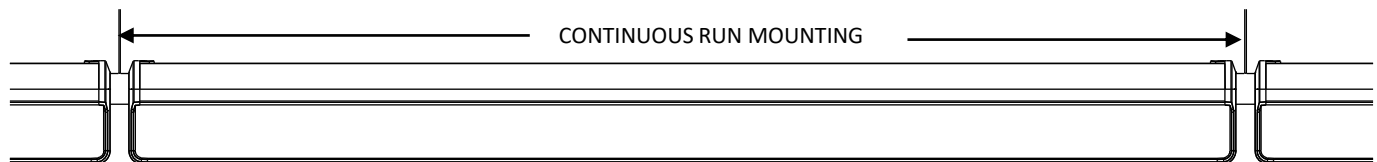

Fixture Length	2ft	4ft	5ft	6ft	8ft
CR mounting	25-5/16"	48-7/8"	60-9/16"	72-7/16"	96"

### 1 Prepare fixtures/install ceiling mounting components

Arrange boxed fixtures on floor in specified mounting locations. Remove fixtures from boxes. Install all ceiling mounting components and grippers using separate installation instructions for Mounting (supplied).

**NOTE: If conditions are dusty/dirty, recommended practice is to leave fixtures in their plastic bags until ready to remove top cap for wiring.**

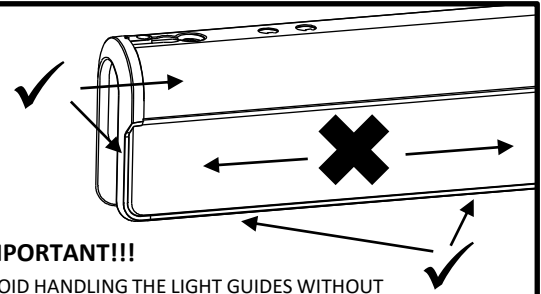

**IMPORTANT!!!**  
AVOID HANDLING THE LIGHT GUIDES WITHOUT WEARING CLEAN GLOVES.

### 2 Remove Top Cap

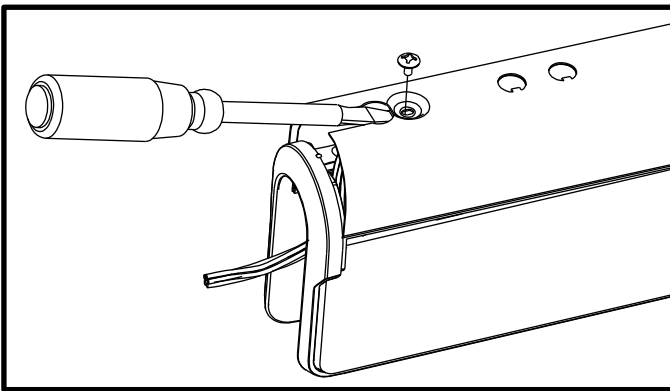

Remove screws along top of fixture with a Phillips or Robertson screwdriver and remove the top cap with the help of a flat head screw driver.

Repeat this for all fixtures prior to mounting.

### 3 Feed Wires into Fixture

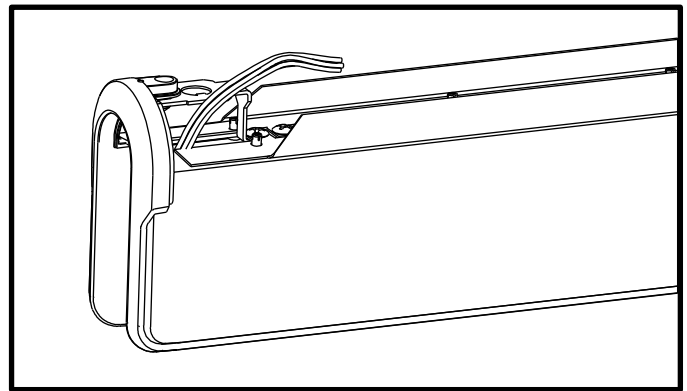

Feed wires into the fixture on both ends of the fixture. Do this for all fixtures on joining ends.

Note: Not required for wires at the ends of the run.

### 4 Mount Joints to Gripper

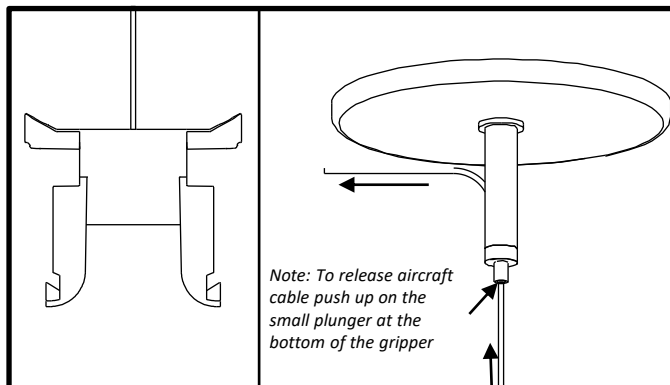

Insert aircraft cable through the joints and mount them in appropriate locations as supplied by layout drawing.

Mount the joints by feeding the aircraft cable through the gripper at the ceiling.

### 5 Insert Aircraft Cable and Mount

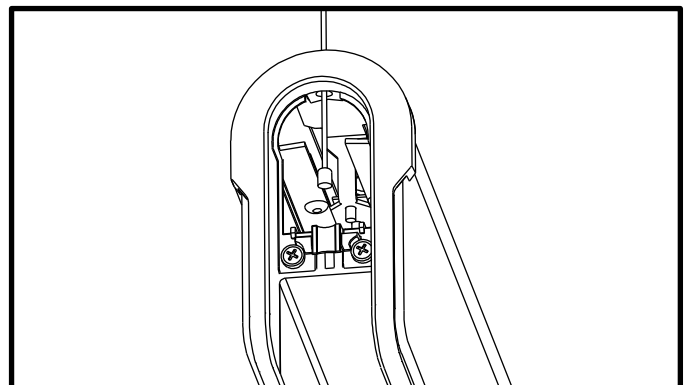

Insert aircraft cable into diecast cross plate. With two people, mount aircraft cable through the gripper as shown in previous step.

For standalone installation skip to step 8.

## 6 Mount Fixture to Joint

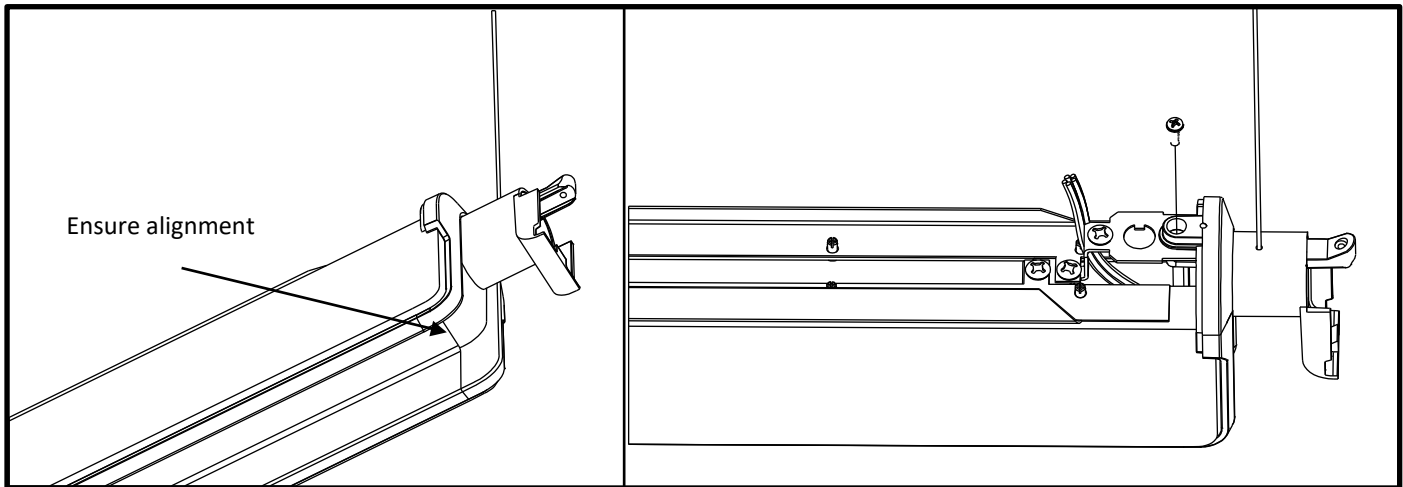

Mount the fixture to the continuous run joint. **Ensure continuous run joint is seated properly in the fixture.** Secure with screw provided in joint kit with a Phillips screw driver.

**IMPORTANT:** Do not over-tighten joiner screws. Ledalite recommends tightening by hand.

## 7 Continuous Run

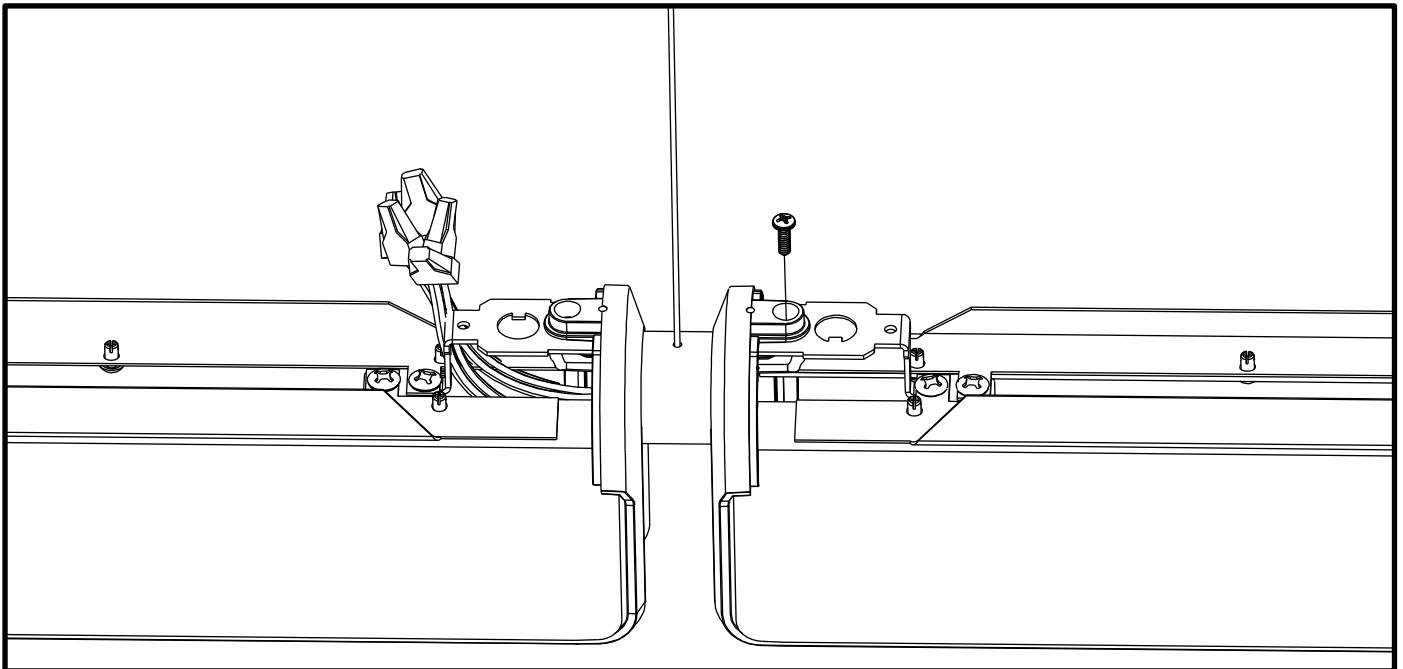

Feed wires from second fixture through the straight joint. Secure with screw provided in joint kit with a Phillips screw driver. Make power connections with supplied quick-wire connectors.

**IMPORTANT:** Do not over-tighten joiner screws. Ledalite recommends tightening by hand.

Repeat steps 6 and 7 for each additional fixture in row.

### 8 Complete Electrical Connections

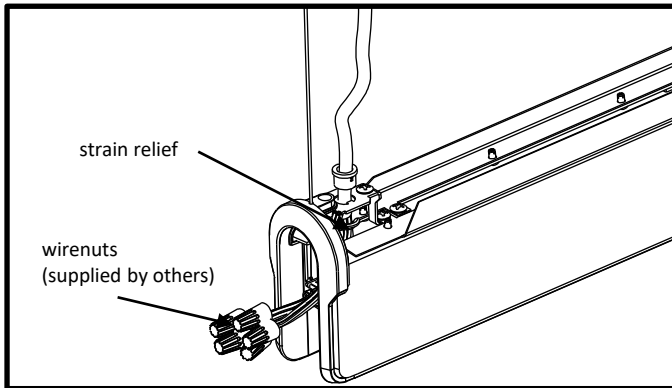

NON-POWER LOCATIONS: Cap all wires and tuck into wire cavity.

POWER LOCATIONS: Remove ½" knockouts as required. Make power drop connection and tuck wires into fixture cavity.

### 9 Close with Endcaps

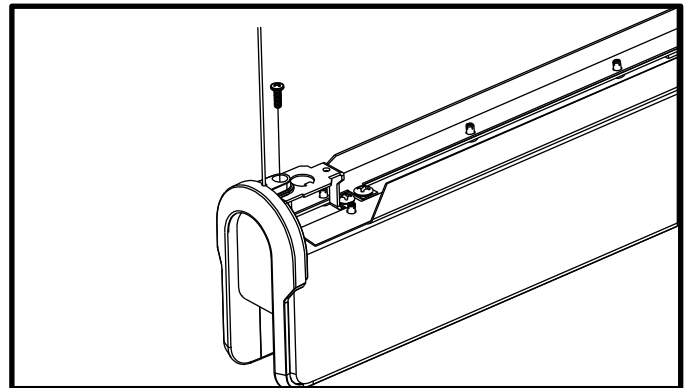

Secure endcaps with screw provided with a Phillips screw driver.

**IMPORTANT:** Do not over-tighten joiner screws. Ledalite recommends tightening by hand.

### 10 Secure Top Cap

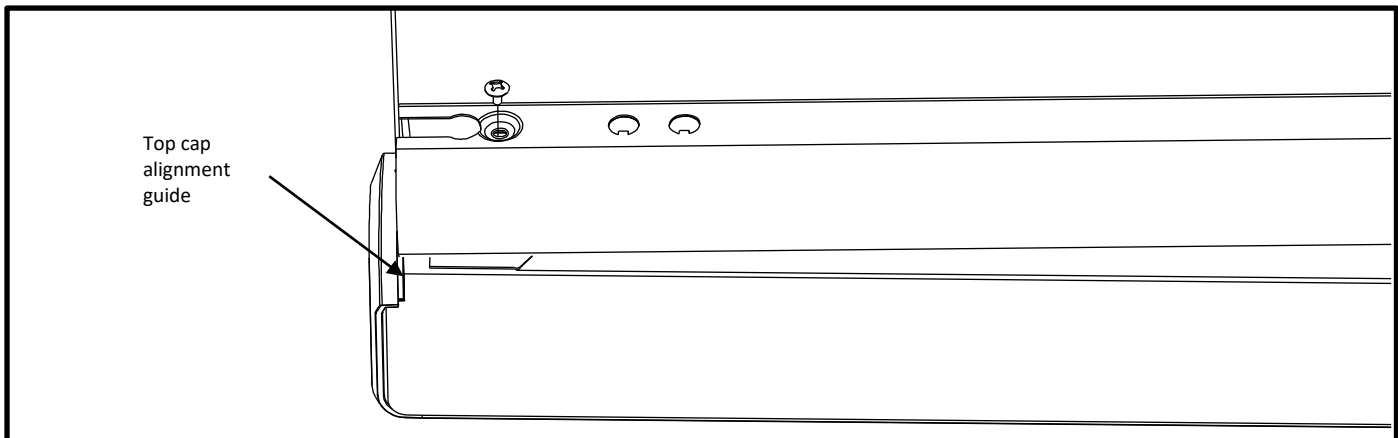

Tuck wires into fixture then replace top caps and secure with screws provided with either a Robertson #2 screwdriver or a Phillips screwdriver.

### 11 Leveling and Cleanup

- Level row by adjustments at the gripper (see step 4).
- Wipe light guide panel clean if required – ensuring to not introduce scratches.

### Sensors in Rows

#### Single Sensor Controlling Whole Row

1. Purple & brown (or purple & grey/pink) control wires **MUST** be connected between fixtures.

Note:

- A maximum of 8 drivers can be wired to one sensor; confirm fixture driver count with factory.

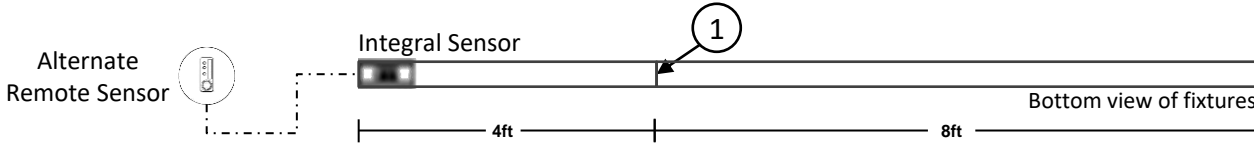

#### Multiple Sensors Controlling Separate Zones in a Row

2. Purple & brown (or purple & grey/pink) control wires **MUST NOT** be connected between zones.

Notes:

- A maximum of 8 drivers can be wired to one sensor; confirm fixture driver count with factory.
- Only one sensor is allowed on a wired zone. (Sensors can be paired together wirelessly via a mobile app).

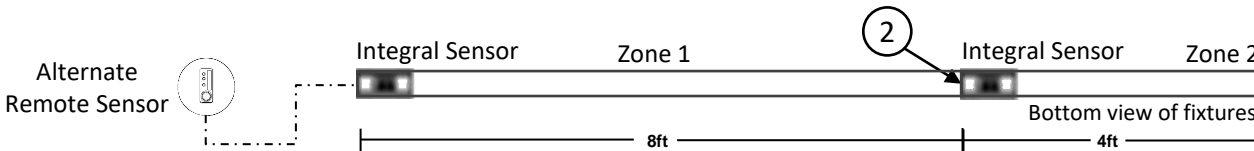

#### Sensor Spacing

- For correct operation, sensors should be placed a minimum distance of 8ft apart.
- Wireless sensors should be placed no further than 40ft apart for good wireless signal connection.

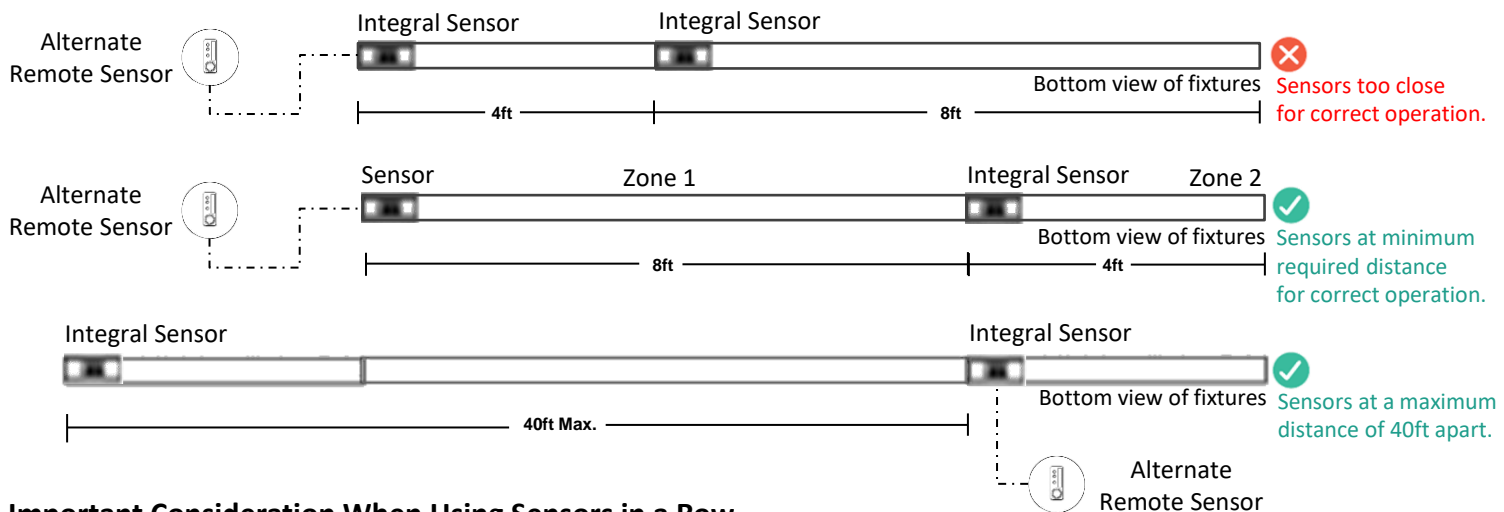

#### Important Consideration When Using Sensors in a Row

- For fixtures with wireless sensors (CS, SB or RA options):  
**DO NOT** connect fixture purple & brown (or purple & grey/pink) control wires to an external dimming switch. Fixture mains wiring should not be connected to a circuit with an external on/off switch.
- For best aesthetic condition, place sensors at ends of row only so as not to break the continuous lens.
- For better occupancy coverage in longer rows, sensors may be placed mid run, but keep in mind this will break the continuous lens into discrete sections. Alternatively, remote sensor may be used, note the same wiring rules will apply.

**! ATTENTION:** Install in accordance with national and local building and electrical codes.

### Occupancy Sensor Coverage:

Note: Longer dimension of detection area (Y1, Y2) is parallel to longer dimension of the luminaire.

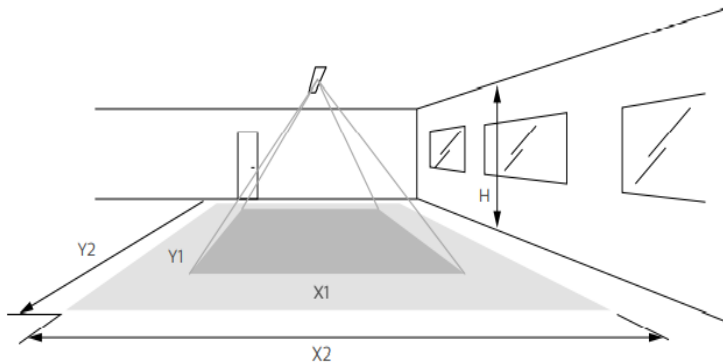

Height	Minor movement		Major movement	
h	X1	Y1	X2	Y2
2.4 m (7.9 ft)	1.9 m (6.2 ft)	2.9 m (9.5 ft)	2.9 m (9.5 ft)	4.3 m (14.1 ft)
3 m (9.8 ft)	2.4 m (7.9 ft)	3.6 m (11.8 ft)	3.6 m (11.8 ft)	5.4 m (17.7 ft)

The detection area for the movement sensor can be roughly divided into two parts:

- Minor movement (person moving  $\leq 3\text{ft/s}$  or  $0.9\text{m/s}$ ).
- Major movement (person moving  $\geq 3\text{ft/s}$  or  $0.9\text{m/s}$ ).

### Daylight sensor

The light sensor measures the total amount of light in a circular field of approximately 80% of the PIR detection area. The following aspects should be observed during installation:

- Minimum distance from the window  $\geq 2\text{ft}$  (0.6m).
- Prevent light reflections from outside entering the sensor (for example sunlight reflection on a car hood) as this will lead to incorrect light regulation.

As a guideline the formula  $0.72 \times H$  can be used to calculate the minimum distance between the window and sensor whereby H is the height from the bottom of the window to the sensor.

### Photosensor spatial response

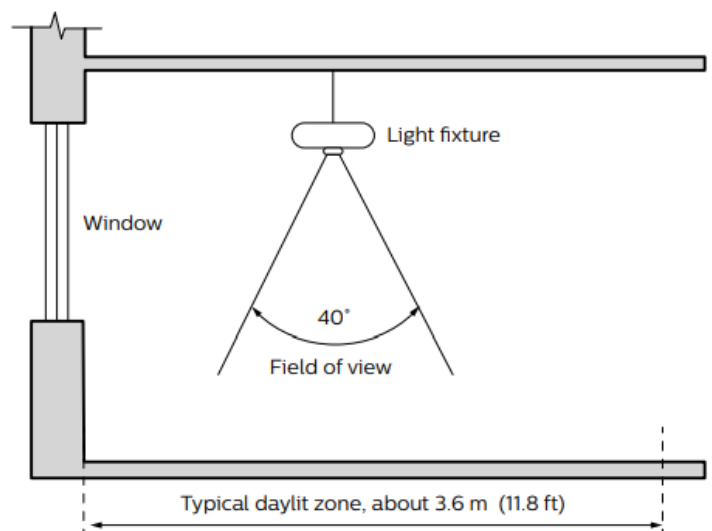

**! ATTENTION: Install in accordance with local and national building and electric codes.**

